

12
P.S.

DCPA CONTRACT No. DAHC 20-70-C-0323

DCPA WORK UNIT 4212A

FEBRUARY 1978

SHELTERS IN SOVIET WAR SURVIVAL STRATEGY

FINAL REPORT

LEON GOURE

CENTER FOR ADVANCED INTERNATIONAL STUDIES
UNIVERSITY OF MIAMI

DDDC
RECEIVED
APR 27 1978
F

AD A 053250

DDC FILE COPY

APPROVED FOR PUBLIC RELEASE; DISTRIBUTION UNLIMITED

Table of Contents

SUMMARY	v
PREFACE	ix
FOREWORD	xi
I. SOVIET POLICY ON SHELTERS	1
II. SOVIET SHELTER CATEGORIES	5
A. Shelter Types	6
1. Super- and Extra Hard Shelters	7
2. Dual-Purpose, Extra-Hard Shelters	9
3. Detached Shelters	10
4. Basement Shelters	15
5. Dual-Purpose, Detached and Basement Shelters	23
6. Quickly-Erected Blast Shelters	24
B. Radiation Covers	27
1. Detached Radiation Covers	27
2. Radiation Covers in Adapted Basements, Cellars and Buildings	30
3. Simple Expedient Radiation Covers	31
III. SHELTER FILTER-VENTILATION SYSTEMS	37
A. Factory-Made Filter-Ventilation Systems	39
B. Simple Filter-Ventilation Systems	45
C. Natural or Gravity-Flow Ventilation	50
IV. SHELTER HABITABILITY	51
A. Air Supply and Temperature Control	51
B. Water and Food Reserves	57
C. Sewage System	59
D. Heating	59
E. Doors and Entrances	60
F. Miscellaneous Shelter Equipment	61
G. Soviet Views on Duration of Shelter Occupancy	62
V. SHELTER AVAILABILITY, READINESS AND COST ..	65
VI. CONCLUSIONS	73

Summary

The provision of blast shelter protection for the urban population and people in potential target areas for nuclear strikes has been a fundamental part of the Soviet civil defense program since the end of World War II. While in the 1960s first priority was assigned to pre-attack evacuation and dispersal of urban residents as a method for protecting the population, in the 1970s shelters have been given primary emphasis, with the stated goal being to develop the capability to "shelter the entire population in protective structures" in the event that there would not be sufficient time to carry out or complete the evacuation. Even so, shelters have been constructed, albeit at various rates, in public buildings, in industry and in apartment houses since the 1950s.

The Soviets distinguish between blast shelters (*ubezhishche*) and radiation or fallout covers (*ukrytie*). Blast shelters vary according to their hardness, capacity, whether built in basements or separate-standing, in the quality of their filter-ventilation system, and whether they are permanent shelters built in peacetime or quickly erected in an emergency. In addition, shelters may or may not be designed for dual-purpose use such as garages, restaurants and canteens, classrooms, rifle ranges, pedestrian or vehicular tunnels, subways, mines, etc.

In terms of hardness the shelters include super or extra-hard shelters for select elements of the elite and as command and control centers, hardened on the order of 1,000 psi blast overpressure; deep shelters such as the subway systems and underground factories; detached shelters at industrial enterprises, office and apartment buildings, hardened in the range of 40-150 psi.; basement shelters in multistory buildings hardened in the range of 40-150 psi; and quickly erected shelters, preferably built of buried precast, reinforced concrete ducts or plates hardened in the range of 10 to 42 psi. Blast shelters provide a protective factor against radiation on the order of 1,000. In terms of occupancy, shelters vary from space for 50 persons to over 1,000 persons, with the more common size being on the order of 150 to 300. The ventilation equipment for shelters includes factory-made filter-ventilation units designed to filter out radioactive dust as well as smoke and toxic chemicals, and various types of simple filter systems, usually operated manually, designed to filter out radioactive dust only. Manufactured filter-ventilation systems may also be provided with blast attenuators, carbon monoxide scrubbers, heat exchanges and air regeneration units. The volume of air required depends on ambient air temperatures and climatic zones, and ranges from 4.1 cubic feet per minute per person to 10.6 cubic feet per minute per person. Simple filters are constructed with sand-gravel, slag and

PRECEDING PAGE BLANK-NOT FILMED

cloth for filtration materials. Large shelters will have stand-by protected diesel-electric generators to operate the filter-ventilation system, while others will be powered by electricity and can be operated manually in an emergency. Quickly erected blast shelters will have simple filter-ventilation systems and can be built in under 72 hours, using mechanized equipment.

Radiation covers are built outside the probable target areas for nuclear strikes. They include adapted basements, cellars, and interior rooms of buildings as well as dugouts constructed of various handy materials, or covered zigzag trenches. Basement covers may be hardened up to 42 psi blast overpressure. Generally the capacity of such covers ranges from a single family to some 50 persons. They provide a radiation protection factor of 200 to 500, or even higher. Radiation covers will be equipped with manually-operated, simple filter-ventilation systems or gravity air-flow systems with simple dust filters.

Permanent shelters are equipped for long-term occupancy by providing blast doors, benches and bunks, toilets, reserves of drinking water, and, in the case of industrial and elite shelters, with stocks of food. The Soviets have set a minimum standard of 2 cubic meters per hour per person of filtered air when using the chemical filter to remove smoke and toxic gases. The actual volume of filtered air provided per person, however, will vary depending on the ambient temperature, climatic zone, and the structural surface area per person available for heat absorption. It is assumed that it will be necessary to operate the ventilation system in this mode (i.e., filtered air) for only a few hours following a strike, after which the system will be switched to filtration of radioactive dust alone (pure air mode), which delivers a larger volume of air to the shelter. The space per person will also vary, not only according to the size of the shelter, but also the requirements for temperature control, and will range from a minimum seating space of 0.5 square meters to some 2 square meters of floor space. The water supply is calculated on a requirement of up to 7 liters per person per day for drinking and 4 liters per person for hygienic purposes. Water is stored in flow-through storage tanks or in non-pressurized containers. Large shelters may have their own artesian wells. In principle, shelters should have sufficient food stocks for at least three days and probably more in the case of prestocked shelters. In the case of shelters without food reserves, people taking cover in them are instructed to bring a three-day supply of food and additional food may be provided for use by shelter occupants from nearby food stores, restaurants and other trade institutions. Permanent shelters will have heating facilities as well as fire-fighting equipment, radiation meters, dosimeters, monometers to measure air pressure in the shelter (which should be greater than that of outside air in order to

prevent seepage of smoke and toxic gases into the shelter), medical supplies, telephones, radio receivers, and emergency lights.

The limitations on food supplies, and possibly also on the capacity of drinking water storage facilities and toilets, will restrict, in many cases, the duration of shelter occupancy to a number of days rather than weeks. Soviet plans, however, do not anticipate that in most situations there will be a requirement for shelter occupancy of more than three to five days' duration. (An occupancy of over five days is recommended when the radiation level ten hours after the detonation exceeds 25 rads per hour.) After leaving the shelter, the population will either be evacuated to safe areas or will remain for an additional number of days in the surviving buildings, which will protect it from the residual radiation.

While precise estimates of ready shelter capacities accumulated since the 1950s in Soviet cities are not possible, Soviet publications and human sources suggest that sufficient shelter space exists in industry, public buildings, schools, hospitals, institutes, stores, transportation, and apartment buildings in Soviet cities to accommodate 53 to 64 percent of the urban population, or on the order of 70 percent of those elements of the population which the authorities deem to be valuable for the preservation of Soviet power, support of the war effort and postwar recovery.

According to knowledgeable human sources, the current cost of construction of blast shelters in basements, multistory buildings, or in factories ranges from 500 to 1,000 rubles per person, with detached shelters costing one-third more than basement shelters. At a rate of 500 rubles per person, the total cost of the estimated ready shelters is on the order of 43 to 51.2 billion rubles, or if prorated over 20 years, the annual cost is on the order of 2.1-2.5 billion rubles. If one assumes that earlier shelters were cheaper and cost on the order of 250 rubles per person, then the total shelter cost to date would be on the order of 21 to 25 billion rubles, and the annual cost over 20 years would be 1 to 1.2 billion rubles. This would not include the cost of extra-hard shelters for the elite nor the cost of making subway systems deeper, or of building hardened industrial or storage facilities. It seems reasonable, therefore, to assume a Soviet average annual investment in shelter construction on the order of 2 billion rubles.

The shift in the 1970s to assigning priority to shelters in the Soviet civil defense program indicates that the Soviets are pretty far along in their shelter construction program. This appears to be confirmed by Soviet statements which suggest that the earlier emphasis on crisis evacuation was due in part to the limited shelter inventory, because it took a long time to develop a substantial ready shelter capacity.

Thus, while the Soviet shelter construction program is not completed at the present time, with the new emphasis on shelter construction it

could be completed, in the opinion of some human sources, in not too many years hence, and in a crisis the Soviets stand ready to supplement existing shelters with the rapid construction of hastily erected blast shelters and radiation covers. With the development of a large ready shelter capacity in potential target cities and areas, the Soviet leadership is acquiring the capability of protecting valuable elements of the population in the event of a sudden outbreak of war as well as avoiding giving the West strategic warning of its intentions, which the massive pre-attack urban evacuation is bound to provide.

Preface

This is a report that was prepared for the Defense Civil Preparedness Agency, Department of Defense, under Contract DAHC 20-76-C-0323, as a part of an ongoing study of Soviet Civil Defense doctrine, plans, programs and capabilities, undertaken by the Center for Advanced International Studies, University of Miami, Coral Gables, Florida.

The purpose of this report is to assess and describe the Soviet shelter categories, their equipment and habitability, Soviet expedient shelters and fallout covers, and indications of the availability of ready shelter space, as well as their cost. The study is based entirely on open sources.

For earlier studies dealing with Soviet Civil Defense plans, programs and activities, the reader should refer to the following reports prepared by this author and published by the Center for Advanced International Studies:

Soviet Civil Defense 1969-70 (June 1971)

Soviet Civil Defense—Urban Evacuation and Dispersal (May 1972)

Soviet Civil Defense—Post-Strike Repair and Restoration (June 1973)

Soviet Civil Defense in the Seventies (September 1975)

War Survival in Soviet Strategy (April 1976)

The Soviet Civil Defense Shelter Program (June 1977)

Foreword

While awareness of the existence of a major Soviet civil defense program has gained ground in the U.S. in recent times, there is still considerable uncertainty and controversy over the precise extent of present Soviet capabilities for protecting the population and economy of the USSR from nuclear strikes, as well as over the quality and effectiveness of Soviet protective measures and facilities. The very newness of U.S. concern over Soviet civil defense has led to the drawing of preliminary conclusions on the basis of incomplete data and limited surveys, and has given rise to controversy over which evidence is proper for use in assessing existing Soviet capabilities.

In a number of instances the preliminary estimates of Soviet shelter hardness, capabilities to sustain long-term occupancy and existing ready shelter space in Soviet cities, which have been aired in public discussions, have tended to seriously underestimate the scope and quality of the Soviet shelter program. For example, some early reports credited the Soviet Union with having ready shelters only for the elite and a portion of the industrial workforce, but none for protecting the general population. Other accounts have portrayed the population protection program as consisting of ordering the urban residents to leave the cities and then to use shovels to dig primitive fallout shelters. Still others, on the basis of a misreading of Soviet manuals, have come to the conclusion that the shelter ventilation systems provided too little purified air to prevent the overheating of the shelters and thus precluded long-term shelter occupancy. Various discussions of the possible effects of U.S. nuclear strikes also have tended to assume low hardness figures for Soviet blast shelters, thus resulting in the drawing of unwarranted optimistic conclusions about the ability of the U.S. to overcome Soviet efforts to protect its population from attack.

Although some brief observations on the scope and character of the Soviet shelter program have been presented by this author in earlier reports such as *Soviet Civil Defense (1969-1970)* (1971); *War Survival in Soviet Strategy: USSR Civil Defense* (1976); and *The Soviet Civil Defense Shelter Program* (1977), the present study attempts an in-depth examination of the official Soviet policies on shelter construction, the design and hardness of various types of Soviet shelters and fallout covers, the equipment of shelters and their capability to sustain long-term occupancy, as well as an estimate of shelter availability and costs, based on open source materials, which includes not only the extensive analysis of Soviet publications, but also interviews conducted by the author with human sources who have personal knowledge of the Soviet shelter program, its scope,

design and construction characteristics and costs. These latter sources have proven invaluable in providing specific information on the scope, character and costs of the Soviet shelter program, and demonstrate that only an all-sources approach to the analysis of this program can provide a comprehensive and realistic picture of Soviet shelter capabilities.

There is no doubt that since the inception of the post-World War II Soviet civil defense program the Soviet authorities have viewed shelters as a highly important, if not critical, element among the measures for protecting the population and economy against the effects of nuclear strikes. Unlike the U.S., where the approach was to identify and mark spaces providing a measure of protection against fallout radiation, Soviet shelters have been designed and equipped mainly to provide a significant measure of protection for the occupants against blast overpressure, heat and fire, immediate and fallout radiation, as well as secondary threats, such as debris, smoke and toxic gases, the latter being delivered either by the enemy or resulting from collateral damage.

Naturally, the Soviet authorities have found that large-scale construction of such shelters is very costly, time-consuming, and requires large amounts of relatively scarce resources. This has not discouraged the authorities from implementing a shelter construction program, but it has had the effect of stretching out the time needed to develop a significant in-place ready shelter capability, and also of generating plans for interim protective measures, such as the pre-attack evacuation and dispersal of the urban population and preparedness in an emergency to supplement ready shelters with rapidly erected simple shelters and fallout cover. Apparently the Soviet ready shelter inventory has grown sufficiently by the 1970s to allow the authorities to assign first priority to the completion of the shelter program, a fact which analysts in the U.S. have been slow to appreciate, their attention and discussions still being largely focused on the Soviet pre-attack evacuation and dispersal measures for the urban population, which have been downgraded in priority in the current Soviet civil defense program. Indeed, since blast shelter construction is the primary factor driving up the cost of civil defense systems and one major reason why many countries claim to be unable to afford such a program, the new Soviet emphasis on shelters is clearly a measure of the seriousness with which the Soviet leadership views civil defense and the possibility of developing a meaningful war-survival capability.

CHAPTER ONE

Soviet Policy on Shelters

In order to justify civil defense measures to protect the Soviet people against enemy attacks with nuclear, chemical and bacteriological weapons, Soviet spokesmen are fond of invoking the authority of the Lenin dictum to the effect that "the first productive force of mankind is the worker, the toiler. If he survives, we will save and rebuild everything . . . but we will perish, if we fail to save him. . . ."¹ Indeed, Soviet military doctrine declares these measures to be critical for the war survival of the Soviet Union and the attainment of victory in a nuclear war. Illustrative of this view is the assertion, published in 1973 by the Chief of USSR Civil Defense and Deputy Minister of Defense, then Colonel General (Army General since February 1977), A. Altunin, that

Under present conditions . . . the preparation of the country's rear for defense against means of mass destruction has become, without a doubt, one of the decisive strategic factors ensuring the ability of the state to function in wartime, and in the final analysis, the attainment of victory.²

Again, in the 1975 edition of his book, *The Armed Forces of the Soviet State*, Politburo member and Minister of Defense, Marshal of the Soviet Union A. A. Grechko noted that "it is impossible to conduct a war without a reliable and functioning homefront," and went on to assert that civil defense measures to "ensure the stability of the operation of the entire national economy and reliable protection of the population throughout the country," constitute a "factor of strategic significance."³ In the Soviet view, therefore, the protection of the population against modern weapons is considered to be an important integral part of the overall Soviet defense posture and war-fighting capability.

Soviet priorities as to choices of methods for the protection of the population against attacks with modern weapons have undergone several changes in the postwar years.⁴ In the 1940s and 1950s first priority

¹V. I. Lenin, *Polnoe Sobranie Sochinenii (Complete Collected Works)*, 5th edition (Moscow: Politizdat, 1958), Volume 38, p. 359.

²Colonel General A. Altunin, "The Main Direction," *Voennye Znaniia (Military Knowledge)*, No. 12, December 1973, pp. 4-5. See also L. Gouré, *War Survival in Soviet Strategy: USSR Civil Defense* (Coral Gables: Center for Advanced International Studies, University of Miami, 1976), pp. 47-57.

³Marshal of the Soviet Union A. A. Grechko, *Vooruzhennye Sily Sovetskogo Gosudarstva (The Armed Forces of the Soviet State)* (Moscow: Voenizdat, 1975), pp. 114-115.

⁴See also Gouré, *The Soviet Civil Defense Shelter Program*, Special Report (Coral Gables: Center for Advanced International Studies, University of Miami, 1977), pp. 2-6.

was assigned to shelters especially for the elite in industry and in potential target cities. By the 1960s the effort to obtain a sufficient inventory of effective blast shelters was found to be too slow and costly, and priority was shifted to pre-attack evacuation and dispersal of urban residents. Throughout the decade this approach was described as being the "principal method of protecting the population."⁵ Shelters were continually being built, however, at industrial, governmental and party facilities, schools, and in housing for the elite elements of society. In the 1970s the order of priorities changed once again to a renewed emphasis on shelters. Altunin referred to it in 1973 as a "decisive" change and announced a new requirement for constant readiness "to shelter the entire population in protective structures."⁶ It was declared that "a plan for sheltering the population in protective structures has been brought to the fore as the most reliable one for saving the lives of people from nuclear armed missiles."⁷ According to Altunin, this had not been possible earlier because of the long leadtime required to build such shelters.

It was impossible in a short period of time to provide the urban population with reliable shelters which would offer protection against all the casualty-producing effects of nuclear weapons. Therefore, initially a primary measure called for evacuating and dispersing the population from the most highly-threatened areas. At the same time measures were taken to build protective structures.⁸

Altunin's statement suggests that the inventory of ready shelters had grown sufficiently to permit such a shift in priorities, even though Soviet spokesmen had claimed earlier that it was too costly to attempt to provide shelters for the "entire population."⁹ Apparently the situation has

⁵K. G. Kotlukov and V. D. Moskalev, *Obiazannosti Naseleniia po Grazhdanskoi Oborony i Pravil Povedeniia v Usloviakh Napadeniia Protivnika (The Duties of the Population in Civil Defense and the Rules of Conduct Under Conditions of Enemy Attack)* (Moscow: DOSAAF, 1966), p. 19. For a detailed discussion on Soviet views on urban evacuation and dispersal see Gouré, *War Survival in Soviet Strategy*, pp. 80-87, and Gouré, *Soviet Civil Defense, Urban Evacuation and Dispersal*, Final Report, Center for Advanced International Studies, University of Miami, DCPA Contract No. DAHC 20-70-C-0309, May 1972.

⁶Altunin, *Sovetskii Patriot (Soviet Patriot)*, November 21, 1973; "An Important Aspect of Training," *Uchitel'skaia Gazeta (Teachers' Gazette)*, August 22, 1974; and "Civil Defense Today," in *Liudi i Dela Grazhdanskoi Oborony (People and Affairs of Civil Defense)* (Moscow: Voendizdat, 1974), p. 9.

⁷K. G. Kotlukov, K. S. Oglabin, and A. I. Sgilevskii, *Grazhdanskaia Oborona Vchera i Segodnia (Civil Defense Yesterday and Today)* (Moscow: Atomizdat, 1975), cited in JPRS, *Translations on USSR Military Affairs*, GUO 32/76, July 8, 1976, pp. 19-20.

⁸Altunin, "Principal Stages and Directions of Development of USSR Civil Defense," *Voenna-Istoricheskii Zhurnal (Military-Historic Journal)*, No. 11, November 1976, p. 45.

⁹V. A. Beliavskii, *Grazhdanskaia Oborona, Vsenarodnoe Delo (Civil Defense, Everyone's Business)* (Moscow: Atomizdat, 1968), p. 9; M. V. Kachulin, *Beseda Naseleniem o Grazhdanskoi Oborone (Conversation with the Population About Civil Defense)* (Moscow: Atomizdat, 1970), p. 32.

changed significantly in this respect. The principal justification, however, for the requirement to "provide the entire population of cities and installations, which are the most likely targets for nuclear strikes," with shelters capable of providing protection against "all casualty-causing effects of nuclear and chemical weapons,"¹⁰ is claimed to be the need to be prepared for a sudden outbreak of war or a very rapidly escalating crisis which might not provide sufficient warning time to carry out the pre-attack evacuation and dispersal of the urban population and operation which, according to Soviet manuals, would require on the order of 72 hours.¹¹ It is asserted in particular that war might begin with a surprise nuclear strike because such a strike is said to confer important and possibly even decisive advantages to the aggressor, and, consequently, USSR civil defense must be prepared "for precisely" such a worst-case as this possibility "is the most dangerous and is fraught with the threat of causing great casualties among the peaceful population."¹² Of course, a capability to shelter the population also reduces the strategic warning to potential enemies of the Soviet Union which would be generated by the evacuation and dispersal and thereby facilitates the implementation of a Soviet first strike strategy, which is an essential element of Soviet military doctrine and a critical factor in Soviet concepts of war fighting and war survival.¹³ This does not mean, however, that Soviet civil defense has dropped the option of pre-attack urban evacuation and dispersal. Thus Altunin points out that "even though civil defense has as its goal to provide all urban residents" in potential target cities "with reliable shelters, evacuation and dispersal measures, as before, will remain among the important measures for the protection of the population."¹⁴ Similarly, a Soviet manual published in 1975 states:

The greatest effect in protection of the populace is achieved by combining methods of shelter [protection] with dispersal and evacuation of people to safe areas of the out-of-city zone. This is why it is extremely important that dispersal and evacuation, as an important component in the complex of missions for protection of the population, are well planned and effectively carried out in compressed periods of time, and to previously prepared [relocation] areas.¹⁵

¹⁰Altunin, *Liudi i Dela Grazhdanskoi Oborony*, p. 8.

¹¹P. T. Yegorov, I. A. Shliakhov and N. I. Alabin, *Grazhdanskaia Oborona (Civil Defense)*, 2nd edition (Moscow: Vysshaia Shkola, 1970), p. 523.

¹²*Ibid.*, 3rd revised edition, 1977, p. 10, English translation. See also Kotlukov, *et al.*, *Grazhdanskaia Oborona Vchera*, p. 19.

¹³See Gouré, *War Survival in Soviet Strategy*, pp. 53-56; and Gouré, F. D. Kohler, M. L. Harvey, *The Role of Nuclear Forces in Current Soviet Strategy* (Coral Gables: Center for Advanced International Studies, University of Miami, 1974), pp. 102-111.

¹⁴Altunin, *Liudi i Dela Grazhdanskoi Oborony*, p. 9.

¹⁵Kotlukov, *et al.*, *Grazhdanskaia Oborona Vchera*, p. 20.

The shift in emphasis from evacuation and dispersal to shelters is also reflected in Soviet civil defense manuals. Whereas prior to 1973 these manuals and instructions to the population listed evacuation and dispersal in first place among measures for the protection of the population, those published after 1973 reversed the order, placing the requirement for the timely construction of shelters in first place, followed by measures to provide the population with "individual means of protection" (i.e., gas masks and protective clothing), and listing evacuation and dispersal last.¹⁶ Confirmation of the shift in priorities is also evident in Soviet reports on civil defense activities by republic civil defense chiefs and other officials. Similarly, a Finnish civil defense official who visited the Soviet Union in 1973 reported that "in recent years ever increasing attention has been paid to shelter protection," and that "since 1970 the construction of shelters has increased."¹⁷ Since 1973 shelter construction has also become an "obligatory" part of the comprehensive civil defense exercises which are held not only at factories and farms, but include entire cities and districts.

The shift to a program of providing shelters for the entire population in potential target areas suggests not only that the Soviet leadership is willing to significantly increase investments in civil defense, but also that in the preceding years sufficient shelters had been built to protect that element of the population whose survival was deemed essential and were given first priority. Soviet data and human reports indicate that such priority was given to the protection of the party and governmental leadership and leading cadres, military commands and headquarters, the party and state control apparatus, including the KGB, important communications facilities, industry, especially defense-related plants and research institutes, and other institutions vital for the preservation of the system, the conduct of war and Soviet recovery as a power. This did not exclude, however, especially in the 1950s, the construction or adaptation of basement shelters in urban housing or the adaptation of subways for shelter purposes, thus creating a capability to protect a certain portion of the general population as well. Thus by 1973, when the shift in priorities was announced, a very substantial ready shelter capability already existed in the potential target cities and at industrial facilities, which the new program now seeks to supplement.

¹⁶For example, compare the 2nd edition of Yegorov, *et al.*, *Grazhdanskaia Oborona*, published in 1970 with the 3rd edition published in 1977, or compare K. G. Kotlukov, Iu. A. Lebedeva, L. I. Gorelov, *et al.*, *Grazhdanskaia Oborona (Civil Defense)* (Moscow: Prosveshchenie, 1972), with the 1976 edition of the same book. An exception to this is the reference to USSR civil defense in *Sovetskaia Voennaia Entsiklopediia*, Volume 2 (Moscow: Voenizdat, 1976), p. 353.

¹⁷Erkki Mantyvaara, *Väestösuojelehti* (Helsinki), No. 12, 1974.

CHAPTER TWO

Soviet Shelter Categories

The Soviet shelter inventory, which has been built over a period of some four decades, includes a wide variety of shelter types and designs. These range from shelters built before, during and immediately after World War II and subsequently reinforced and re-equipped to provide protection against nuclear weapons, to standardized designs developed in the 1970s, including also a variety of dual-purpose shelters and adapted existing underground structures.¹⁸

The basic distinction the Soviets draw is between shelters (*ubezhishche*) and simple cover (*ukrytie*). Shelters are defined as protective structures which can provide various measures of protection against all direct and collateral casualty-causing effects of nuclear, and in most cases, chemical weapons. They also provide a radiation attenuation factor of 1,000 or more. Covers are designed mainly to provide protection against radiation from nuclear fallout. Shelters are built in peacetime in potential target areas for nuclear strikes, while covers are used predominantly to protect people in small towns and rural areas which are unlikely to be the target of a direct enemy attack. The Soviets draw the following distinctions between shelters and covers and their use:

The provision of covers and shelters for the entire population is being planned and carried out in a differentiated manner according to their types and protective features. The plans provide that workers and employees of major cities and important national economic installations who continue to work in wartime as the basic productive force are to be provided with cover in shelters which will protect them against all destructive effects of nuclear weapons. In addition, at the appearance of a threat of enemy attack, it is possible to use as shelters basements, deep facilities, and structures adapted for this purpose, and also the simplest shelters (slit trenches, dugouts, covered trenches, and so on). The latter are erected by local resources in places of residence and work.

Depending on the situation, in small towns and populated centers in the rural areas it is possible to take shelter in fallout covers set up in basements, cellars, vegetable storage cellars, mine shafts, and natural caves. It is also possible to use other underground facilities and specially constructed covers (dugouts, covered trenches, and so on) for these purposes.¹⁹

¹⁸Iu. Iu. Kammerer and A. E. Kharkevich, *Ekspluatatsiia Ubezishch Grazhdanskoi Oborony (Use of Civil Defense Shelters)*, 2nd edition (Moscow: Literatura po Stroitel'stva, 1970), p. 6; and also various reports by human sources.

¹⁹Kotlukov, *et al.*, *Grazhdanskaia Oborona Vchera*, p. 20.

A. Shelter Types

Soviet publications also provide distinct classifications for shelter and cover types on the basis of several criteria. According to recent Soviet manuals, shelters are classified "in terms of their protective properties, capacity, location, availability of filter-ventilating equipment, and in terms of time of erection."²⁰ The latter category is new. It was not included in the 1970 edition of the same manual. These classifications are further broken down as follows:²¹

In terms of protective properties shelters are divided into five classes according to the degree of protection they provide against the shockwave of nuclear detonation.

In terms of capacity (the number of persons taking shelter), shelters are divided into: small-for up to 150 persons, medium-for 150 to 450 persons, and large-for over 450 persons.

In terms of location, shelters can be built-in or separate-standing. The built-in shelters include those located in the basements of buildings, and the separate-standing ones are those located outside of buildings.²²

In terms of filter-ventilating equipment, the shelters can have factory-made filter-ventilating equipment or simplified equipment made from available materials.²³

In terms of time of erection, shelters are either built ahead of time, in peacetime, or rapidly erected and built at the time of a threat of an attack [i.e., when the leadership believes a threat of war to exist, prior to the actual attack].²⁴

Soviet publications do not specify the "five classes" of shelter hardness. The literature suggests, however, that these classes designate various distances from ground zero of a nuclear detonation at which shelters with various degrees of hardness would survive the blast overpressure. Early Soviet publications measured hardness in terms of the distance from ground zero of a nuclear air burst, designated as R, at which an unprotected person would survive unharmed. According to this scheme, survival at ground zero was assured "only in underground shelters," while specially built basement and separate-standing shelters were said to be safe, according to their degree of hardness at 1/10 to 1/6 R, and a dugout type shelter at 1/3 R from ground zero. Similarly, more recent Soviet publications assert that a shelter hardened to withstand 1 kg/cm²

²⁰Yegorov, *et al.*, *Grazhdanskaya Oborona*, 3rd edition, 1977, in English translation.

²¹*Ibid.*

²²*Ibid.* The 2nd-edition, p. 178, published in 1970, mentions "five classes," while the 3rd edition says only that "shelters are divided into classes."

²³*Ibid.* The second (1970) edition, on p. 178, also mentions that shelters can have natural air circulation "without filter-ventilation." This is omitted in the third (1977) edition.

²⁴This category was not mentioned in the 2nd (1970) edition.

(14.2 pounds per square inch-psi) of blast overpressure would survive at 2.8 to 3 km from ground zero of a one megaton yield air burst nuclear detonation, and a shelter hardened to 2 to 3 kg/cm² (28.4 psi to 42.6 psi) would survive at 1.5 to 2 km from ground zero.²⁵ There are likely to be categories of hardness for shelters able to survive at ground zero and at less than 1 km from ground zero. Indeed, Soviet publications mention various ranges of shelter hardness from 0.5 kg/cm² to 10 kg/cm² (7.1 psi to 142 psi),²⁶ although they fail to discuss shelters designed to withstand higher blast overpressures.

According to human sources, high grade concrete is used in the construction of shelters, especially for the roofs. The quality of Soviet concrete is graded from 100 to 600, representing the amount of compression the particular concrete can withstand, which is expressed in kg/cm². Shelters utilize components made of 400-500 grade concrete (i.e., with a compression ratio of 5,680 psi to 7,100 psi), and special shelters may utilize 600 grade concrete (i.e., with a compression ratio of 8,520 psi).²⁷ Steel rods in very large amounts are generally used to reinforce the concrete.

1. *Super and Extra-Hard Shelters*

Whether the "five classes" of shelter hardness mentioned in Soviet literature include super-hard shelters, which are built for the use of the leadership, other essential civilian personnel, military command posts and special installations, is not known. Such shelters are not only very deep, but, according to human sources, the walls and roofs are several meters thick, and may even be lined with a sheet of lead. The existence of large-capacity shelters of this type, hardened to withstand on the order of 1,000 psi blast overpressure, is reported by knowledgeable U.S. and Soviet sources.²⁸

In the 1950s and 1960s, Soviet civil defense publications discussed and described several types of "special" extra-hard shelters. There were said

²⁵Kachulin, *Beseda*, p. 26.

²⁶P. G. Iakubovskii, *Grazhdanskaia Oborona (Civil Defense)*, 5th edition (Moscow: Prosveshchenie, 1972), p. 26; N. P. Krechetnikov and M. P. Olovianishnikov, *Grazhdanskaia Oborona na Mashino-Stroitel'nykh Predpriatiakh (Civil Defense at Machine-Building Enterprises)*, 2nd edition (Moscow: Mashinostroenie, 1972), p. 27; A. A. Gromov and N. P. Krechetnikov, *Grazhdanskaia Oborona Promyshlennogo Obekta (Civil Defense at an Industrial Enterprise)*, 2nd edition (Moscow: Atomizdat, 1975), p. 35.

²⁷Standard quality concrete used in buildings has a compression ratio of 3,000 to 3,500 psi.

²⁸For example, see the *New York Times*, January 3, 1977; The Joint Chiefs of Staff, letter to Senator William Proxmire, January 28, 1977, cited in the Congressional Record-Senate, January 31, 1977, p. S1780.

to be three types of such shelters, all designed to withstand high blast overpressures and to accommodate "several thousand" persons each. All such "special" shelters were of the detached or separate-standing type. The three types of extra-hard shelters discussed in the literature included:

1. The solid-type (*sploshnoi*) shelter, built entirely of cast reinforced concrete with walls and roof "several meters thick," is similar to a World War II bunker. Such a shelter could be partially aboveground or entirely subterranean. Because it was said to be intended to accommodate large numbers of occupants, it had several floors and was equipped for a prolonged occupancy.

2. The layer-type (*sloisty*) shelter was a separate-standing shelter located entirely underground and covered with earth. It was built of reinforced concrete but the walls and roof were thinner than in the solid-type shelter. Apart from the layer of earth above the shelter, additional protection was provided by a thick plate or slab of reinforced concrete several meters thick, placed above the actual roof of the shelter and extending beyond it, with the ends anchored to shelves cut into the ground. This shielding slab was, in turn, covered with earth. This type of shelter was also designed to accommodate large numbers of persons and had several floors. It also was equipped for long-term occupancy.

Extra-Hard Shelters

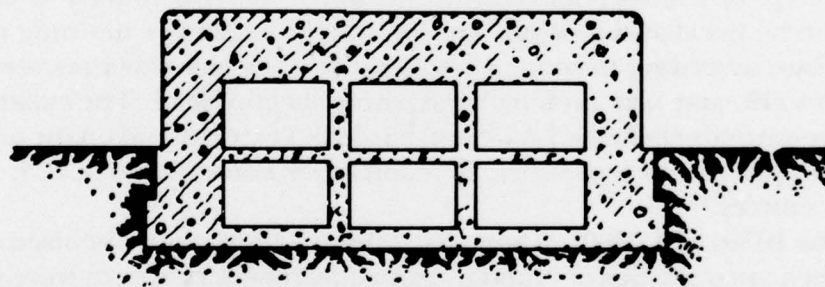

Solid Type

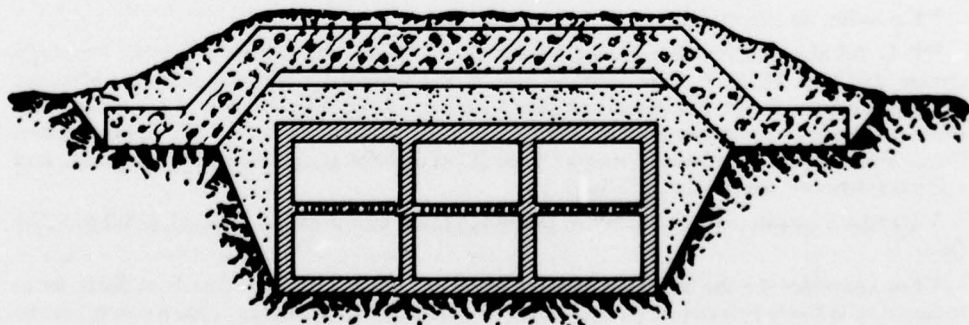

Layer Type

3. The deep underground tunnel-type shelter is located at a depth of 20-40 meters (65 to 131 feet) with vertical stairs or horizontal incline ramp entrances.²⁹ The tunnel complex is faced with concrete or built of large-diameter reinforced concrete pipes. Such deep shelters were said to best withstand blast overpressure at or near ground zero of a nuclear detonation.³⁰ It was suggested that this type of shelter could be best built in hilly terrain in the form of galleries into the hillside, but it could also be built like mineshafts in flat terrain.

Although Soviet publications failed to specify the hardness of these "special" shelters, and precise hardness estimates are impossible to make in the absence of more detailed information on their construction, their design indicates that they would be able to withstand well in excess of 142 psi blast overpressure, and possibly in excess of 300 psi.³¹ In essence, these shelters were designed to survive at or near ground zero of a one megaton yield air burst nuclear weapon.

Soviet publications made clear, however, that, because of the high cost of construction, these "special" shelters were not intended for the general use of the population. No specific mention was made concerning when such shelters would be built or for what category of people they were designed. Following a decade and a half of the mention of these "special" shelters, often accompanied by schematic sketches in Soviet publications, references to them ceased abruptly after 1966. The significance of this is not clear. There is no reason to believe, however, that this reflects a loss of interest by the Soviet authorities in the construction of extra-hard shelters. It seems more likely that because these shelters are intended for the use of select personnel, the authorities decided to discontinue discussing them in civil defense publications for the general population.

2. *Dual-Purpose, Extra-Hard Shelters*

Unlike the case of specially built extra-hard shelters, Soviet publications continue to identify various dual-purpose, deep underground structures for use as shelters by the population. Foremost among them are the deep sections of the subway systems in a number of Soviet cities. Some Soviet manuals equate the subways with the underground tunnel type

²⁹V. P. Sinitsyn and G. A. Malin, eds., *Zashchita ot Sredstv Massovogo Porazheniia (Protection Against Means of Mass Destruction)* (Moscow: Uchpedgiz, 1958), p. 91.

³⁰L. F. Supron and F. P. Zverev, *Meditinskoe Obespechenie Naseleniia v Usloviakh Primeneniia Sredstv Massovogo Porazheniia (Medical Service for the Population Under Conditions of the Use of Means of Mass Destruction)* (Minsk: Gosizdat BSSR, 1959), p. 308.

³¹See the Honorable Clyde Doyle, Appendix, *Congressional Record*, February 20, 1961, p. A-1079.

of extra-hard shelter, and, at least in the late 1950s, they asserted that in terms of hardness, the subway "surpasses all other types of shelters."³² There are subway systems in operation or under construction in Moscow, Leningrad, Kiev, Tbilisi, Baku and Khar'kov. For example, in 1976 the Moscow subway system had a total length of 160 kilometers (about 100 miles), and is constantly being further extended into the new outlying districts. The deep subway stations are equipped with blast doors at the entrances to the station platforms and in passageways connecting different subway lines. According to reports by Soviet human sources, a branch line extends under the Kremlin, thus allowing the leadership and cadres working there to be evacuated from the city through the subway system. Human sources also indicate the existence of tunnels next to and parallel with sections of the subway for use as "special" shelters and for the storage of food and other supplies. The present Moscow subway may have sufficient capacity to shelter in excess of one million of the city's residents.³³

In addition to the subways, Soviet publications and human sources mention the adaptation for shelter purposes of various types of transportation tunnels, mines, caves and galleries in hills and mountainsides, as well as deep underground pedestrian walkways and shopping malls, which may qualify as extra-hard type shelters. Deep underground factories would also be in this category, and according to reports by people who have recently left the Soviet Union, they are either built as multistory underground complexes or as tunnels into mountainsides. Human sources also report the existence of deep multistory shelter complexes under various military headquarters, as well as under buildings for important party and governmental agencies.

3. *Detached Shelters*

The types of shelters most widely available to the urban population are detached and basement shelters. Both types have been described in Soviet literature since the late 1940s, and there is a large body of evidence showing that such shelters have been built in large numbers. The hardness varies according to their design and the construction materials used

³²M. Gvozdaev and V. Ia. Iakubovskii, *Atomnoe Oruzhie i Protivo-atomnaia Zashchita (Atomic Weapons and Anti-atomic Defense)* (Moscow: DOSAAF, 1958), p. 178. See also, P. G. Iakubovskii, *Grazhdanskaia Oborona, Uchebnoe Posobie dlia Professional'no-Tekhnicheskogo Uchilishch (Civil Defense, Instruction Handbook for Professional-Technical Schools)* (Moscow: Vysshiaia Shkola, 1966), p. 48.

³³Khrushchev is reported to have boasted that the subway system in Moscow was the largest nuclear shelter in the world. H. Schellhammer, "Die Problematik des Luftschutzes und Atomzeitalter," *Wehrkunde*, No. 3, 1959, p. 145.

and, according to Soviet publications, ranges from 1 kg/cm² to 10 kg/cm² (i.e., 14.2 psi to 142 psi).³⁴

Detached or separate-standing shelters, as a rule, are built where it is impractical to locate them under existing buildings, or in order to supplement existing basement shelters. They appear to be especially common at industrial enterprises where production buildings are not equipped with basements. According to human sources, such shelters are more expensive to build than basement shelters, and they have the added disadvantage of taking up extra ground space, which is not always available. As a rule, detached shelters are located sufficiently far from nearby buildings to prevent their being buried under debris, in the event of the latter's collapse. Consequently, they are built most often in factory yards, parks and squares, in the garden strips between apartment buildings, or other open spaces.

The usual detached shelter is a single-story underground structure with space for 150 and up to 1,000 persons. Normally, it is equipped for long-term occupancy. In peacetime such shelters may be used for manufacturing or storage purposes, and in this event are equipped with loading ramp entrances.

Soviet publications indicate that a significant change occurred in the design of detached shelters at the end of the 1950s. Prior to this time the roofs of detached shelters consisted of two separate slabs of cast reinforced concrete. One slab was horizontal, resting on the shelter walls and supporting pillars, which stood three to six meters apart (i.e., 9-18 feet). The other slab was placed above it, meeting it at the outside edges but forming a peak or gable at the center, thus leaving a triangular space between the two slabs. The top slab, in turn, was covered with a layer of 0.80 meters to 1.20 meters of earth (i.e. 2.5 to 4 feet). The shelter was entirely underground, with the floor being three meters (nearly 10 feet) or more below ground level.³⁵ In Soviet sketches, however, the earth placed on top of the shelter formed a mound, with banked sides and flat at the top. These shelters were equipped with two entrances with covered staircases at opposite ends of the shelter. Large capacity shelters could have more entrances. Inside, the shelter was partitioned into a number of compartments for occupancy by 50 to 75 persons each, and was equipped with airlocks at the entrances, each with a double metal door, one or more filter-ventilation units, toilets, etc.

Later, published Soviet shelter designs omitted the double roof concept. Instead, the roofs were pictured as a single horizontal slab of rein-

³⁴Iakubovskii, *Grazhdanskaia Oborona*, 5th edition, p. 26. The 1976 edition of this book omits this reference to the hardness of shelters.

³⁵Kammerer and Kharkevich, *Eksploatatsiia Ubezhisich*, p. 28.

forced concrete, covered with a mound of earth. The roof was supported by the shelter walls and pillars three or six meters apart, or by bearing partition walls. Depending on the levels of the ground water and soil conditions, the shelter could be entirely underground, with the earth cover being even with the surrounding surface of the ground, or it could be partly aboveground with the earth cover forming a noticeable mound. Where the top of the shelter is even with the ground level, it may be used as a volleyball court or be part of a walkway or terrace, etc.

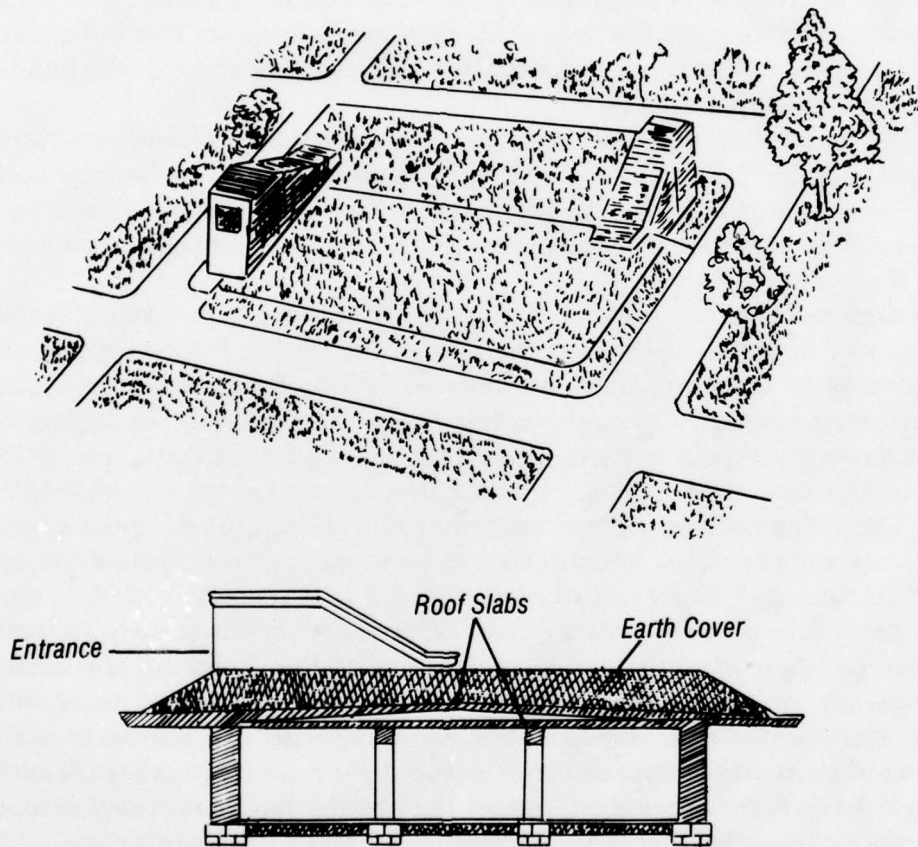

Old-Type Detached Shelter

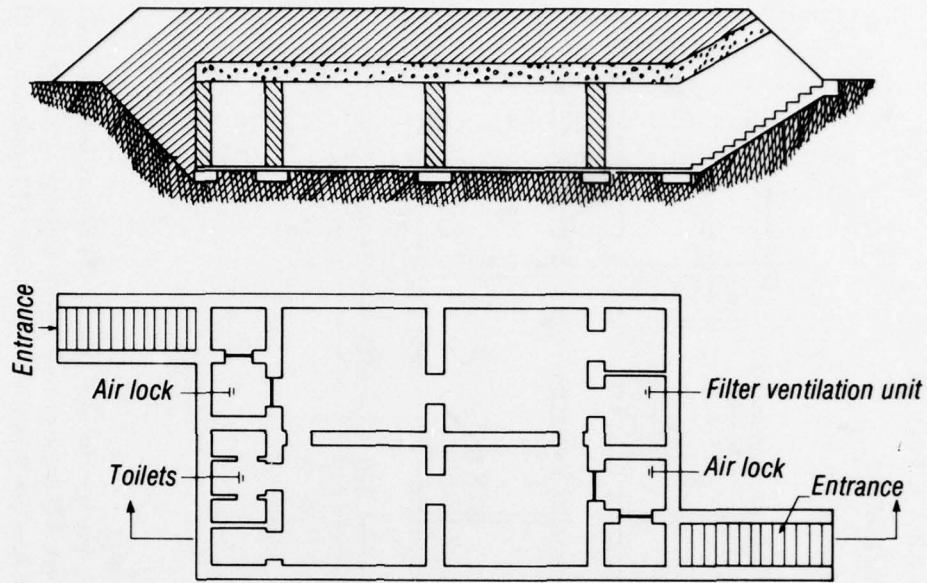

Current-Type Detached Shelter

The number of entrances to these shelters varies according to the capacity. For example, a 900-person capacity shelter, which is also used for manufacturing purposes, is described as having three stairwell entrances and one loading ramp.³⁶ Normally, the air intake and exhaust for such shelters is located in small, round or cubical concrete structures with openings covered with louvered wooden panels on top of the shelter.³⁷

³⁶I. A. Onufriev and A. S. Danilevskii, *Spravochnik Inzhenera-Stroitel'ia (Construction Engineer's Handbook)* (Moscow: Stroizdat, 1970), cited in JPRS, *Translations on USSR Military Affairs*, No. 1240, July 14, 1976, pp. 2-3.

³⁷Kammerer and Kharkevich, *Ekspluatatsiia Ubezhisich*, p. 28. The author personally observed such shelter air intakes while traveling in the Soviet Union.

Plan View of Shelter for 900 Persons and Used as
Auxiliary Shop at Industrial Enterprise

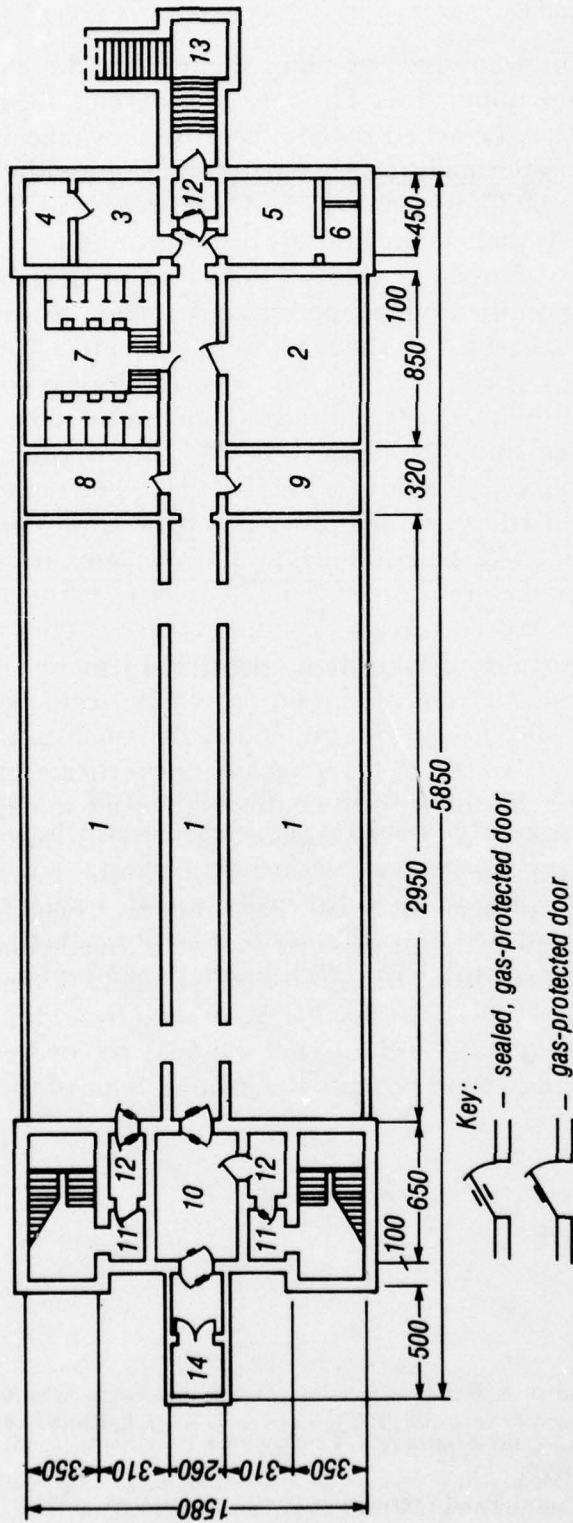

(Dimensions in Centimeters)

(1) areas for persons taking shelter—shop; (2) ventilating room; (3) diesel power plant; (4) area for fuel supply; (5) area of artesian well, second-lift pumping unit and tank for storing water; (6) filter and counterexplosion rooms; (7) sanitary unit and fecal pumping station; (8) medical room; (9) storeroom; (10) lock (after the shelter is full of people, it is used as an area for persons taking shelter); (11) preentry; (12) entry; (13) entry serving as emergency exit; (14) loading hatch of shop.

4. *Basement Shelters*

Soviet sources indicate that basement shelters are the most common type available to the population. They are considered to be cheaper and simpler to build than detached shelters because they take advantage of the excavation work normally carried out in connection with the construction of multistory buildings, and of the foundation and bearing walls. As a rule, basement shelters are entirely below ground level.

The hardness of basement shelters, like that of detached shelters, varies, depending on the design, specific construction features and materials used. The walls of such shelters are from 0.5 to 1.2 meters thick, usually constructed of concrete blocks or cast reinforced concrete. The roofs of basement shelters are required at a minimum to be able to bear the weight of the collapsed building above them. Most often, such roofs are 12 centimeters to 50 centimeters thick (i.e., 4-1/4 inches to 20 inches), and are constructed of cast reinforced concrete or fabricated reinforced or prestressed concrete U-beams, squad beams, or plates. In large shelters the roof is supported by reinforced concrete pillars, on the order of 0.65 meters to the side, placed three or six meters apart. The cast concrete roof may also incorporate fabricated reinforced concrete U-beams or steel I-beams. The roof may also be supported by steel I-beams resting on the walls and pillars. It is recommended that such beams be faced with concrete to prevent them from becoming overheated in the event of a fire. According to human sources, there is a space some 0.70 meters high between the roof of the basement shelter and the floor of the structure above, which is filled with sand, slag or other inert material to provide additional protection against radiation and heat from fires.³⁸ Some roof designs provide for two layers of reinforced concrete with a layer of sand between them. In the case of old shelters built before or during World War II, the roof may be reinforced by additional steel or reinforced concrete pillars, and the roof slab may be covered with a 0.3 meter layer of earth or sand beneath the ground floor of the building.³⁹

³⁸See also Kammerer and Kharkevich, *Ekspluatatsiia Ubezhihshch*, p. 13; Onufriev and Danilevskii, *Spravochnik*, pp. 14, 15.

³⁹For example, see Supron and Zverev, *Meditsinskoe Obespechenie*, p. 313.

Basement Shelter

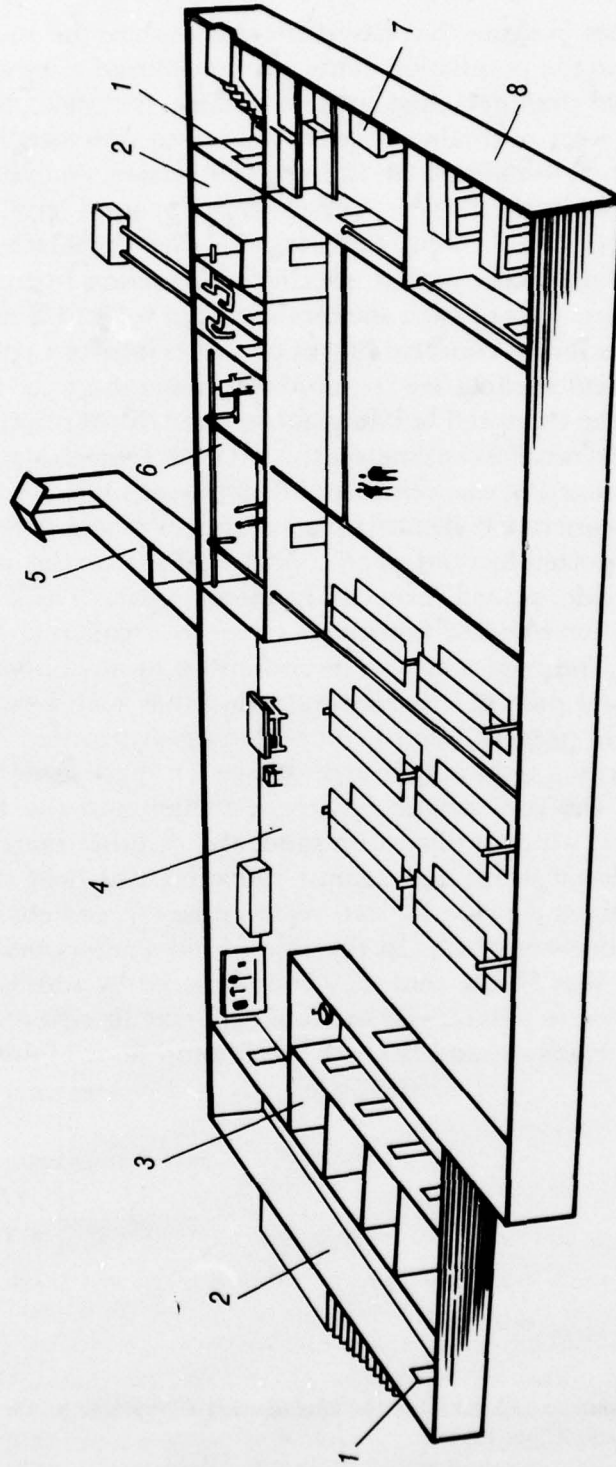
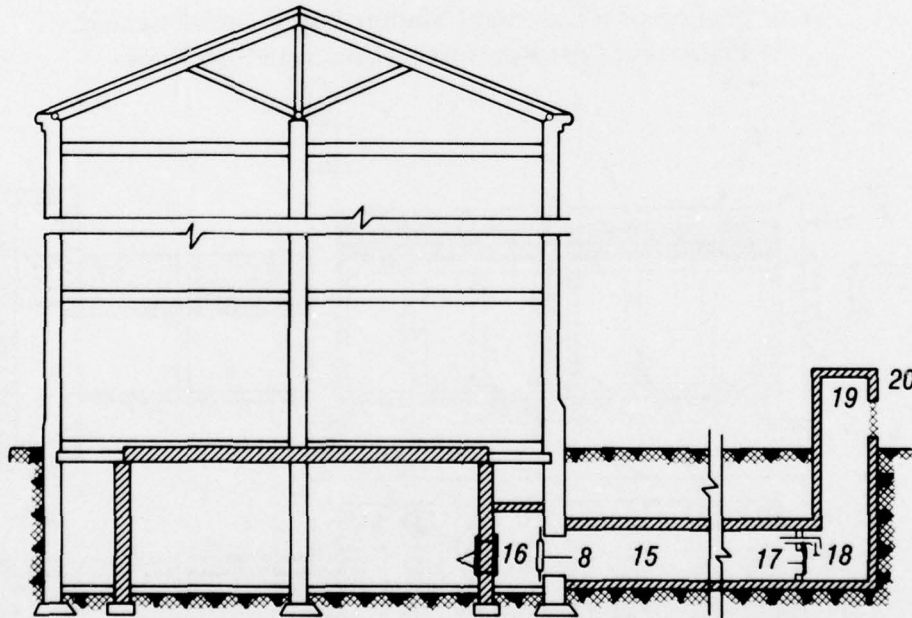
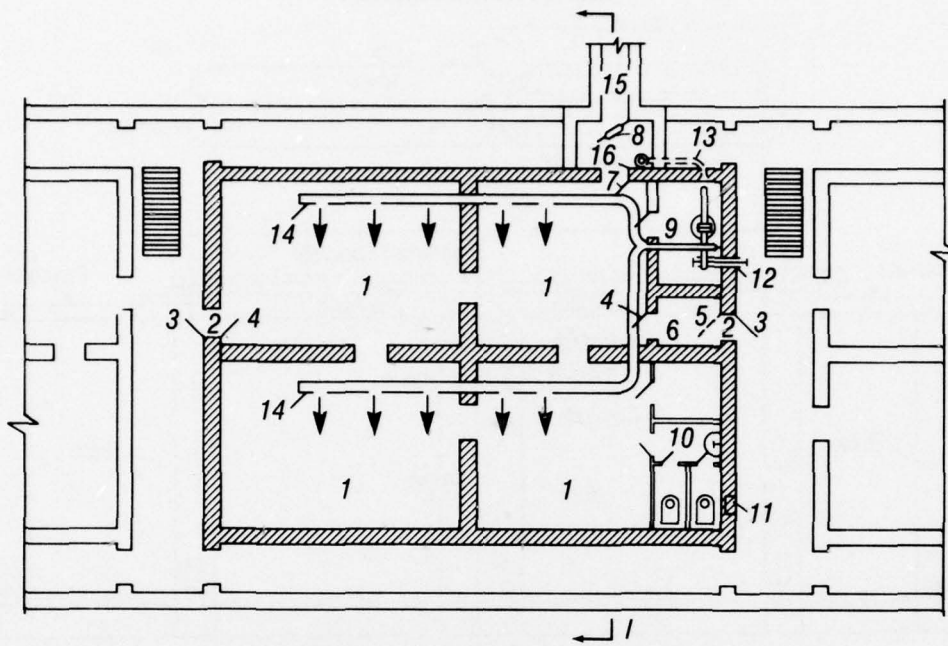

Diagram of a Basement Blast Shelter

(1) protective airtight door; (2) air lock; (3) lavatories; (4) areas for shelter occupants; (5) tunnel and vent cap of the emergency exit; (6) filter-ventilation compartments; (7) medical room; (8) storeroom for food.

Basement Shelter



Basement Shelter in the center of a building basement: (1) compartments; (2) exits; (3) and (4) protective airtight doors; (5) lowered wooden door; (6) vestibule; (7) protective airtight shutters; (8) shutter with dust filter; (9) filter-ventilation chamber; (10) lavatories; (11) exhaust duct; (12) sealing safety valve; (13) basic air intake duct; (14) pressurized pipes; (15) emergency exit; (16) adjoining chamber; (17) airtight safety shutter in emergency exit; (18) floating cutoff valve; (19) vent cap of the emergency exit; (20) wooden lower grating.

Basement Shelters

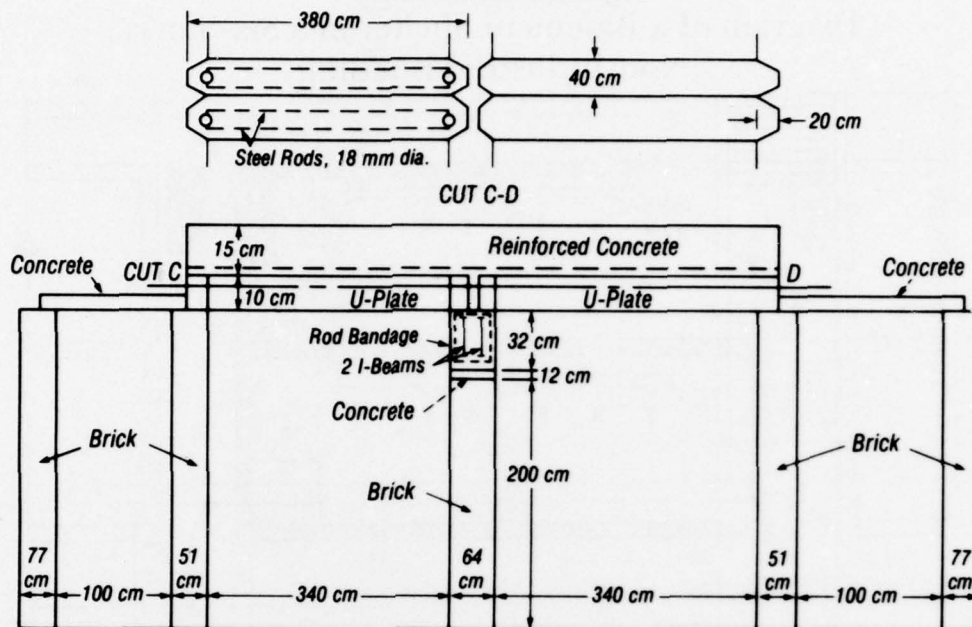

Cross Section of a Basement Shelter Using Prefabricated U-Plates and Cast Reinforced Concrete Slab Roof

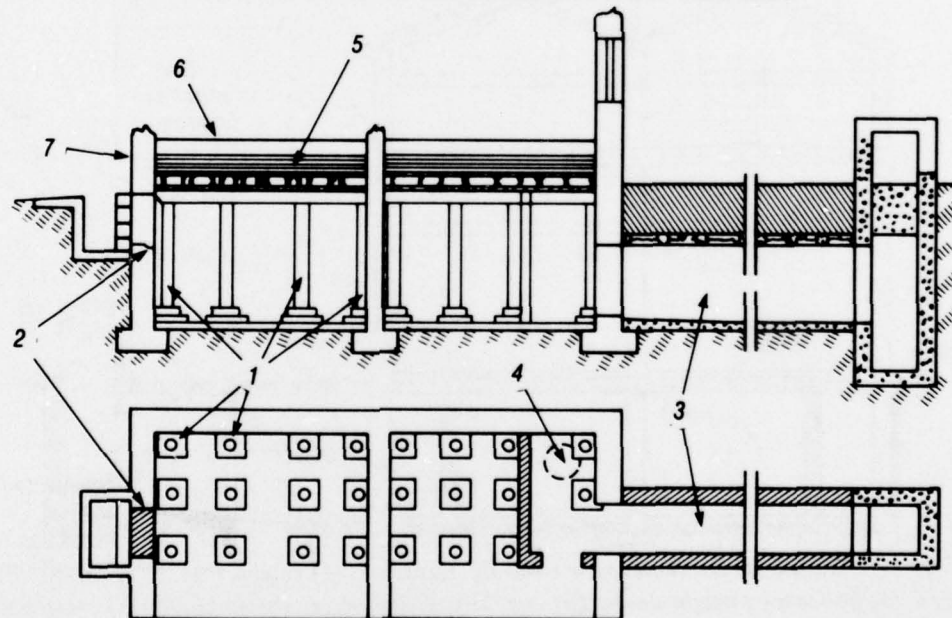

(1) posts (dia = 20 cm); (2) covered windows; (3) emergency tunnel; (4) filter-ventilation unit; (5) wooden boards to guard against splinters; (6) layer of earth (30 cm) to reduce instant radiation; (7) concrete slab

Adaptation of a Basement to Serve as a Shelter

Diagram of a Basement Shelter in a Six-Story, Non-Industrial Building

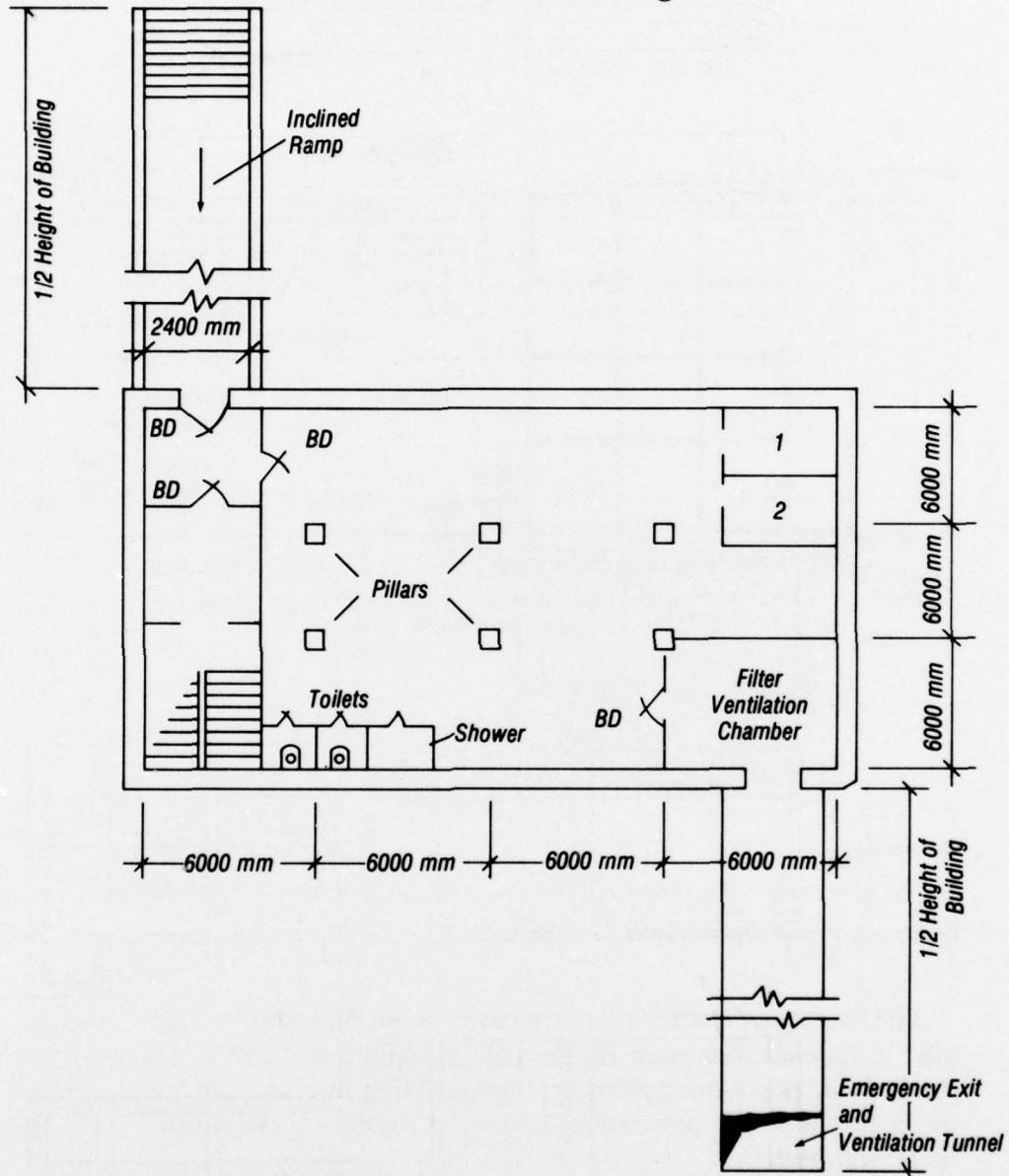

(1) storage for reserve of drinking water; (2) storage for a five-day supply of food; (BD) hermetically-sealing metal doors, height 1.8 m

Pillars of reinforced concrete 0.65 m × 0.65 m × 3 m

REMARKS: All dimensions are in millimeters

Diagram of a Basement Shelter in a Six-Story Non-Industrial Building

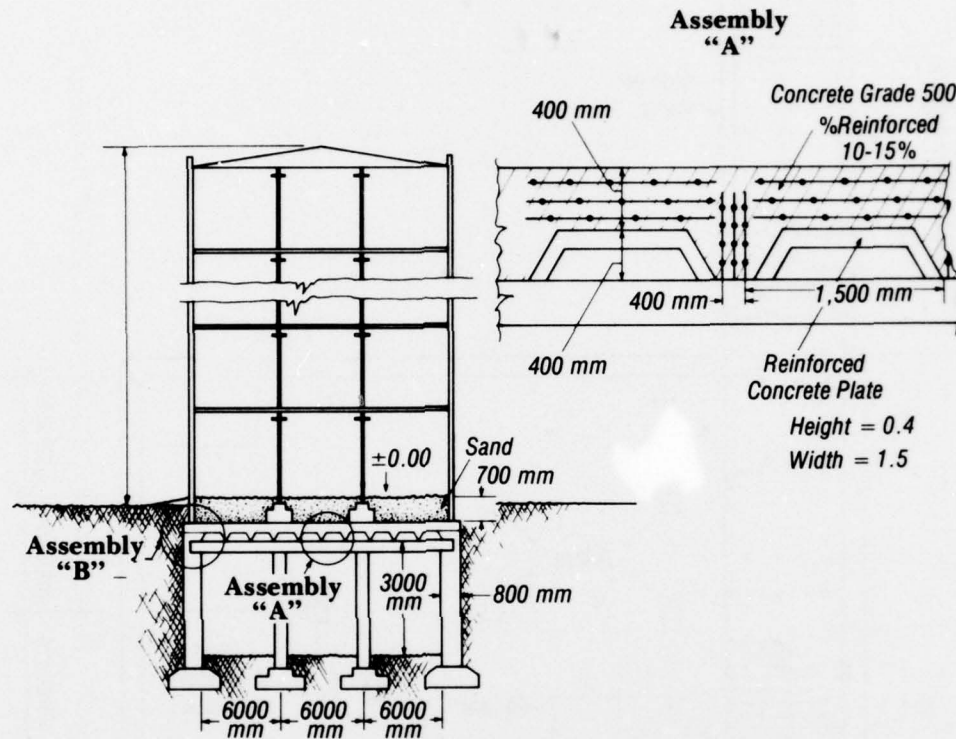

Remarks:

1. The dimensions of the shelter roof are independent of the height of the building.
2. Waterproofing depends on local conditions.

The basement shelter capacity varies from 50 to 500 or more. Generally, it appears that such shelters are designed for 150 to 300 persons. Such shelters are normally partitioned inside into compartments for 50 to 75 persons. The permanent basement shelters are equipped for long-term occupancy.

A particular design feature of basement shelters is their emergency exits, which also serve as an air-intake for the filter-ventilation system. As a rule, the emergency exit heads must be sufficiently distant from nearby buildings to prevent their being buried under the debris. The standard distance from buildings for such exit heads prescribed in Soviet manuals is half the height of the building plus three meters. The exit

Diagram of a Basement Shelter in a Six-Story Non-Industrial Building

Assembly "B"

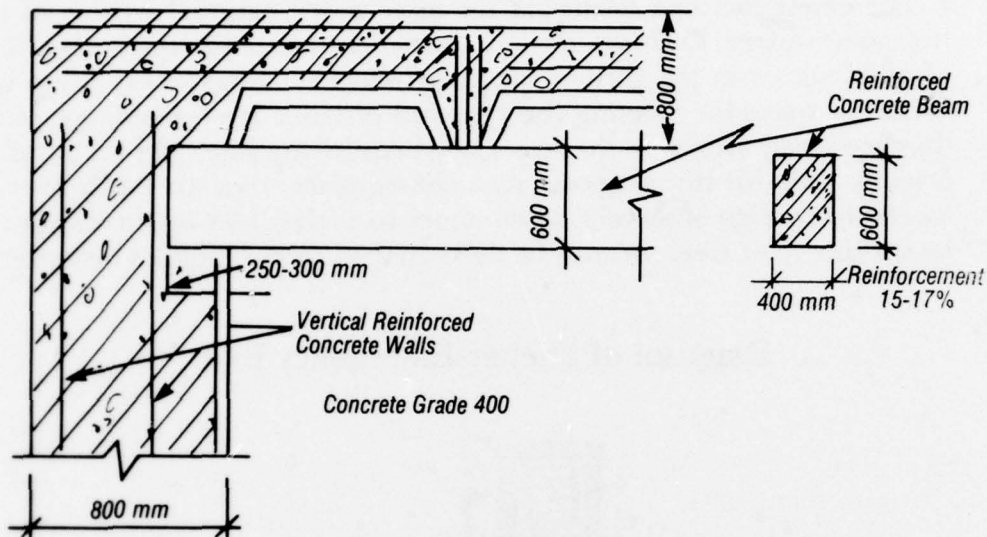

heads consist of a concrete structure about 0.9×0.9 meters to the side (but sometimes 1.2×1.2 meters), and 1.2 to 1.4 meters high, with variously shaped roofs, or they may be circular, 0.9 to 1.2 meters in diameter. The exit heads have one or more openings, usually 0.6×0.8 meters, equipped with inward-opening louvered wooden covers. In special cases, when the surrounding structures do not permit the exit heads to be at the required minimum distance from nearby buildings, the height of the concrete structure may be considerably greater in order to place the opening above the expected level of debris. In some cases, an exception is made and the exit is located against a building or even forms a part of the exterior wall of the building. The exit head is connected to the shelter by a tunnel at least 0.9 meters wide and 1 to 1.6 meters high, or 1.2 meters wide and 2 meters high, and not less than 0.40 meters below ground surface.⁴⁰ The roof of the tunnel is usually constructed of cast or fabricated reinforced concrete plates 0.25 meters thick, while the walls may also be built with reinforced concrete plates or with anchored brick, 0.51 meters thick.⁴¹ At the shelter end the tunnel is

⁴⁰Onufriev and Danilevskii, *Spravochnik*, pp. 4-5; M.N. Titov, P. T. Yegorov, B. A. Gaiko, *Grazhdanskaia Oborona (Civil Defense)* (Moscow: Vysshiaia Shkola, 1974), p. 36; Yegorov, *et al.*, *Grazhdanskaia Oborona*, 3rd edition, p. 107, in English translation.

⁴¹Onufriev and Danilevskii, *Spravochnik*.

closed by two hermetically-sealing metal doors, one on each side of the shelter wall. Although every basement shelter should have at least one emergency exit, Soviet publications indicate that in some situations several shelters may be interconnected by tunnels, with only one of them having an emergency exit.⁴²

The emergency exit heads are the most visible external portion of a basement shelter. Even so, they are most often located in the backyards of buildings or in the garden spaces between buildings where there is sufficient space for meeting the required distance from buildings, but they are rarely visible on the street side because the sidewalks are insufficiently wide for this purpose. As a consequence, they are easily overlooked by foreign observers, all the more so as they may be surrounded by shrubbery or trees, or may be decorated by placing statues or flower

Diagram of Shelter Emergency Exit

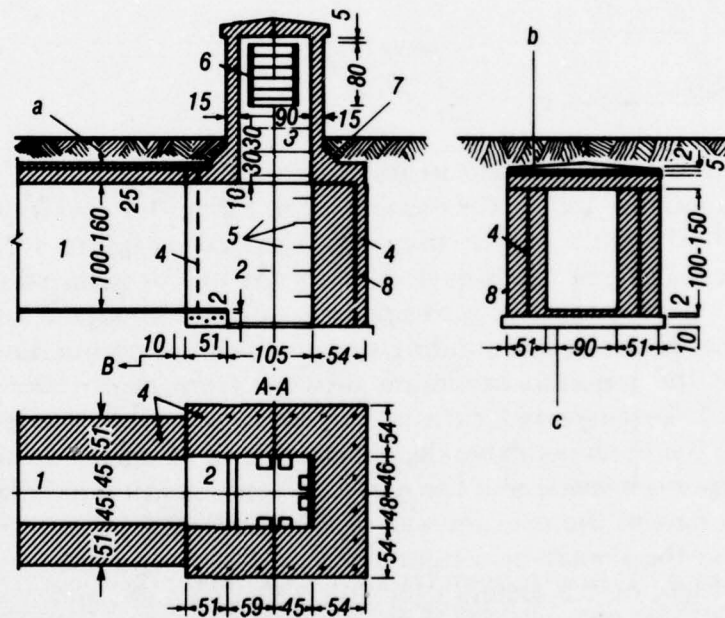

(1) tunnel; (2) chamber; (3) head; (4) anchors; (5) brackets; (6) louvers; (7) coated with hot bitumen twice; (8) brick work; (a) at least 40 cm; (b) coated with hot bitumen twice; tightened with cement; site-cast reinforced concrete; prefabricated reinforced concrete crosspiece; (c) cement floor; concrete preparation.

⁴²Ibid.

containers on top of them, or they may be used as a base for slides and other play equipment for children.⁴³

5. Dual Purpose Detached and Basement Shelters

The Soviet authorities recommend a dual purpose use of detached and basement shelters. Specifically, it is said that they should be used in peacetime as garages, stores, workshops, laboratories, movie theaters,

Shelter in a Pedestrian Walkway

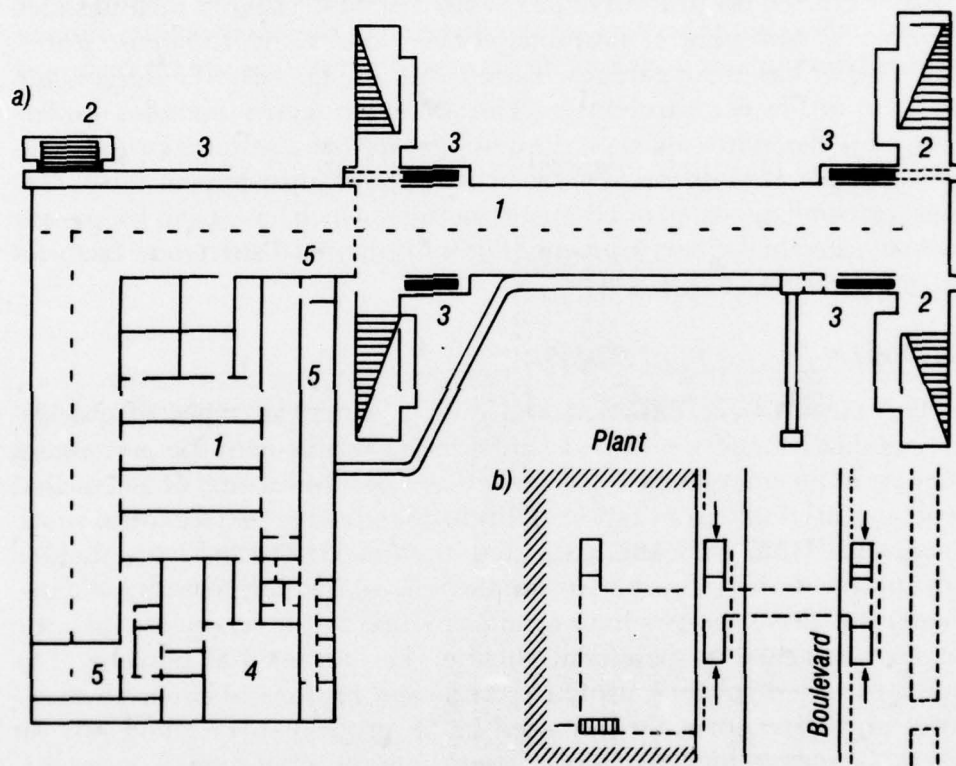

(a) Diagram of the shelter-walkway; (1) shelter compartments; (2) stairs; (3) hermetically-sealing, protective doors concealed in the walls; (4) diesel-electric generator; (5) filter-ventilation chamber; (6) pumping station; (7) toilets; (8) control point for access to plant; (b) Diagram of location on the ground.

⁴³Kammerer and Kharkevich, *Ekspluatatsiia Ubezishch*, p. 47. Concerning the difficulties observers have had in identifying these structures as emergency shelter exits, see Gouré, *The Soviet Civil Defense Shelter Program*, p. 4.

restaurants, offices, classrooms, rifle ranges, storage facilities for non-combustible materials, cloakrooms, and so on.⁴⁴ Shelter space can be rented for such purposes with the approval of the executive committee of the local councils and the shelter services of the appropriate civil defense staffs, with provisos ensuring that the equipment will be maintained in operational readiness and that if the shelter is used for storage it can be cleared in a few hours.⁴⁵

According to Soviet literature and human sources, there are three types of dual-purpose shelters. The first is built especially for this purpose, the second takes advantage of an underground structure to add a shelter, and the third consists of regular shelters where the available space is utilized for peacetime purposes. The first category includes such facilities as basement restaurants, coffee houses and canteens, stores, detached or basement garages, basement movie houses, rifle ranges, and in some instances, warehouses. The second category includes underground pedestrian walkways, tunnels, underpasses, sewer conduits, utilities tunnels, and so on. Of particular significance appear to be the underground detached or basement garages, which have been frequently incorporated in the development of new residential districts and factories during the 1960s and 1970s.⁴⁶

6. *Quickly-Erected Blast Shelters*

The Soviets have designed and built a variety of types of quickly-erected blast shelters, which are intended to supplement the permanent shelters in an emergency. Such shelters are predominantly of a detached type and are built from fabricated reinforced concrete structural units. As distinct from permanent shelters, the quickly-erected blast shelters are equipped with fabricated or simple filter-ventilation systems and fans. Generally, these shelters have a smaller capacity for occupants than the regular detached or basement shelters, i.e., under 100 persons. The quickly-erected shelters, using prefabricated reinforced concrete structural units, are normally emplaced below ground surface and rely on 0.6 to 1.0 meter-thick earth cover over them for additional protection.⁴⁷

⁴⁴Altunin, *Liudi i Dela Grazhdanskoi Oborony*, p. 9; Yegorov, et al., *Grazhdanskaia Oborona*, 3rd edition, p. 105 of English translation.

⁴⁵Kammerer and Kharkevich, *Ekspluatatsiia Ubezishch*, pp. 50-51.

⁴⁶*Ibid.*, pp. 29-30, 140; L. Diubek, "A Model Housing District in Northern Chertanovo," *Arkhitektura SSSR (USSR Architecture)*, No. 3, 1973, p. 10. At the Northern Chertanovo development in Moscow, the project called for garage space for 3,000 passenger cars for some 20,000 residents.

⁴⁷F. I. Ostroukh, *Stroitel'stvo Bystrvozvodimykh Ubezishch i Protivoradiatsionnykh Ukrytii (Construction of Quickly-Erected Blast and Anti-Radiation Shelters)* (Moscow: Voenizdat, 1972), p. 17.

The most common prefabricated reinforced concrete units used in building such shelters include large diameter sewer and water conduits (1.5 - 2 meters in diameter), square sewer conduits and non-through ducts, sewer blocks or large dimension concrete blocks, as well as plates or slabs of various thicknesses (up to 22 cm for flat units and 39 cm for ribbed units).⁴⁸ The shelters are usually provided with right-angle entrances and double hermetically-sealing doors "designed to take the same loads as the basic elements of the shelter." According to Soviet publications, such shelters can withstand from 0.7 to 3 kg/cm² (i.e., 9.9 psi to 42.6 psi) blast overpressure.⁴⁹ Published Soviet photographs of quickly-erected shelters under construction show the shelter walls being built with large dimension concrete blocks, two to three feet in height and width, and some five feet in length.⁵⁰ These shelters are said to provide a radiation protection factor of 400 to 1,000 at the interior door, with most types in the 800 to 1,000 range.⁵¹ Such shelters can be built in under 72 hours with the use of mechanized construction equipment such as excavators, bulldozers and cranes. Soviet authorities suggest that the quickly-erected shelters, built in peacetime as a part of training exercises, be further improved and strengthened, provided with regular filter-ventilation units, electric power, and so on, so as to transform them into permanent shelters.

⁴⁸*Ibid.*, pp. 25, 45-46; Yegorov, *et al.*, *Grazhdanskaia Oborona*, 3rd edition, p. 19 of English translation; *Voennye Znaniia*, No. 2, February 1970, p. 49.

⁴⁹*Ibid.*; Iakubovskii, *Grazhdanskaia Oborona*, p. 30.

⁵⁰For example, see *Voennye Znaniia*, No. 5, May 1975, p. 39.

⁵¹Ostroukh, *Stroitel'stvo*, pp. 28-31.

Expedient Shelters

Shelters made of pipes (diameter 1.5, 2, 2.5, or 3 meters)

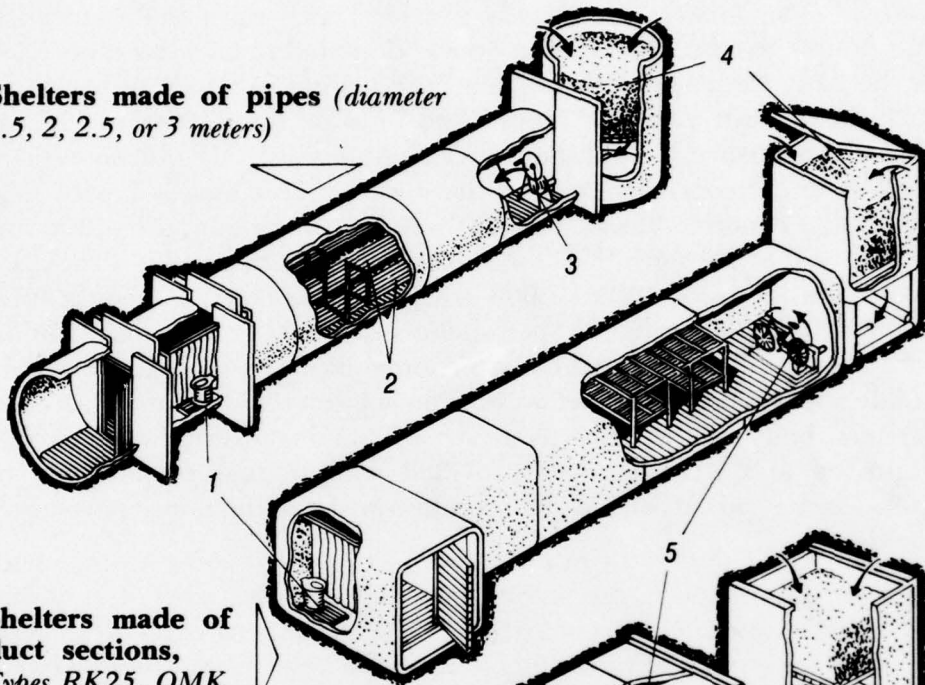

Shelters made of duct sections,
Types RK25, OMK
2.4 x 2.4 m. TB-3

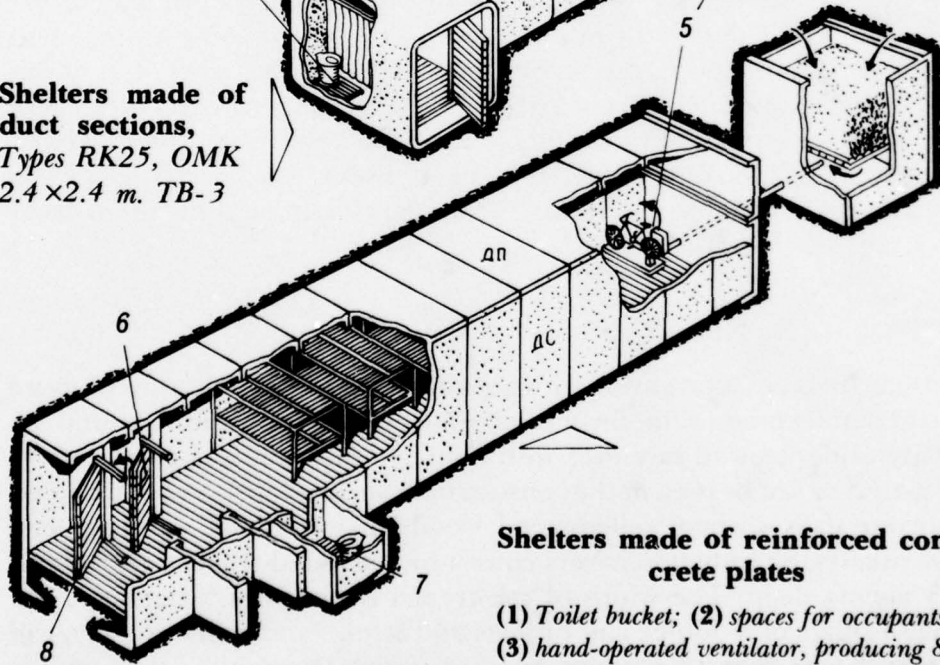

Shelters made of reinforced concrete plates

(1) Toilet bucket; (2) spaces for occupants; (3) hand-operated ventilator, producing 8-120 m³/hour of air; (4) filter made of sand, slag, with capacity of 150-220 m³/hour of air; (5) bicycle; (6) hermetic-sealing doors with air valve; (7) toilet; (8) protective door with hermetic seal

B. Radiation Covers

Radiation covers are primarily intended to provide protection against radioactive fallout, and consequently should be the principal method for protection of the population in areas not threatened by blast and fire from nuclear detonations, i.e., in small towns and rural areas. Because covers are to be used in less densely populated areas, there is less need than in the cities for large capacity protective facilities. Consequently, radiation covers will generally be designed for occupancy by less than 50 persons. At the same time, the structural requirements for providing a shield against radioactive fallout are much simpler than the requirements for blast protection, with the result that there is a great variety of designs for radiation covers using a large assortment of materials as well as all sorts of existing structures. Depending on the characteristics of the covers and materials used, they will provide various levels of radiation protection. Because of their relatively simple construction, radiation covers need not necessarily be built in peacetime but can be quickly acquired when the leadership believes a threat of war to exist. As a rule, covers will have simple air filters and ventilation systems.

There are said to be three categories of anti-radiation covers, which are classified according to the degree of protection from radiation that they provide. The first includes radiation covers providing a protection factor of 200 or more, the second provides a protection factor of 50-200, and the third, a factor of 20 to 50.⁵² In terms of construction, there are three basic types of radiation covers: detached covers, adapted basements and cellars, and simple expedient covers. All three types can be erected rapidly and would be built mainly by the local population, using a variety of materials at hand.

1. *Detached Radiation Covers*

Detached radiation covers with a capacity for 10 to 50 persons or more are generally built in the form of dugouts, either fully underground, or partly underground in places with high ground water. A great variety of materials can be used in the construction, such as fabricated reinforced concrete slabs, sheet or rolled metal, wood, fascine, adobe, sandbags, etc. Essentially, the radiation covers consist of excavated trenches some 2 to 2.3 meters deep. The width of the trench depends on whether it will have a single or a double row of seats and bunks, and, consequently, will range from 1.5 to 2.4 meters. Another factor determining the width is

⁵²Kotlukov, *et al.*, *Grazhdanskaia Oborona*, p. 20.

the hardness of the soil. If the soil is sufficiently hard and dry so that the walls of the trench do not require shoring, the trench can be narrower. The length of the trench depends on the number of persons who will occupy the cover. The length of the trench will not be less than 3 meters and more often is 5-6 meters for occupancy by 10 persons, and up to 9 meters for 20 persons, allowing space for ventilation arrangements and toilets.⁵³ For larger occupancy the radiation cover may be arranged in the form of two trenches intersecting with each other at right angles, in the form of a cross.⁵⁴ In addition to shoring the walls where required, the trench is roofed over and covered with earth. Where wood is used, the construction can be of continuous frame, frame-block, frame-panel, mitered, crown, or unnotched.⁵⁵ The diameter of the beams used in such construction is on the order of 8-16 cm. In areas devoid of forests, 20×20×40 cm adobe blocks, made of clay mixed with pulverized straw, can be used to build up walls in the shelter and domed roof. Fascines of flexible tree branches, rushes or reeds, or agricultural plant stalks can also be used. These materials are tied into circular bundles or arches, 15-25 cm in diameter, which are then emplaced as a continuous frame in or over the trench. The roofs of the covers are then waterproofed with one or more layers of rubberoid or plastic material and/or covered with a 10-20 cm layer of compacted clay, which, in turn, is covered with a 0.5 to 0.8 meter layer of earth. The covers will have straight or right-angle entrances, preferably the latter, either in the form of inclines with steps or shafts with upright ladders. There will be at least one, but preferably two doors, 0.8×1.8 meters, forming an air-lock vestibule. If one door is used, there will be two curtains to shield occupants against radioactive dust.

According to Soviet literature, some types of detached radiation covers can withstand from 1 to 2 kg/cm² blast overpressure (i.e., 14.2 psi to 28.4 psi).⁵⁶ The degree of radiation protection provided by these covers depends on the design of the entrance and the thickness of the earth cover over them. The dugout-type of radiation cover having a right-angle entrance and 0.6 to 0.8 meter of earth cover is said to provide a radiation protection factor of 200 to 500.⁵⁷

⁵³V. I. Molodykh, A. A. Nikanorov, E. I. Korotkevich and P. A. Koshelev, *Protivoradiatsionnye Ukrytiia v Sel'skoi Mestnosti (Anti-radiation Covers in Rural Areas)* (Moscow: Voenizdat, 1972).

⁵⁴Yegorov, *et al.*, *Grazhdanskaia Oborona*, 2nd edition, p. 211; Titov, *et al.*, *Grazhdanskaia Oborona*, p. 43.

⁵⁵Yegorov, *et al.*, *Grazhdanskaia Oborona*, 3rd edition, p. 124 in English translation.

⁵⁶*Ibid.*, 2nd edition, p. 208; Ostroukh, *Stroitel'stvo*, p. 65.

⁵⁷Titov, *et al.*, *Grazhdanskaia Oborona*, p. 41; Kachulin, *Beseda*, p. 57; Ostroukh, *Stroitel'stvo*, pp. 51, 52, 55, 56, 58, 61, 62; Molodykh, *et al.*, *Protivoradiatsionnye*, pp. 29-33.

Dugout-Type Shelter or Radiation Cover Built of Round Timber, With Space for 40 Persons

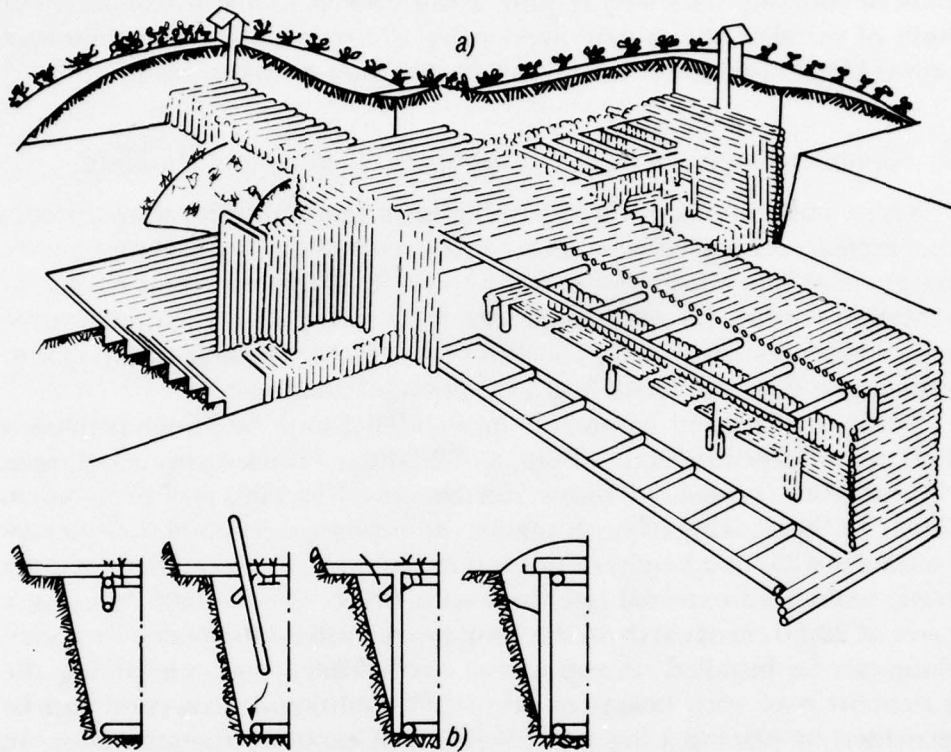

(a) General view;

(b) Assemblies

Soviet publications also mention the possibility of using flexible materials or rigid frames in the construction of radiation covers. For example, it has been suggested that radiation covers be constructed with 1.8×1.8 meter log frames (18 - 20 cm diameter), placed 0.7 meters apart, with the upper and lower spaces cross-braced every 1.4 meters, and that the frames be covered with flexible material, such as three or four layers of canvas, or with sheets of a synthetic material covered with rubber. It is claimed that when such a structure is placed in a trench and covered with earth it can withstand from 1.5 to 2 kg/cm² blast overpressure.⁵⁸

The amount of time and labor required for the construction of detached radiation covers depends on various factors, such as the hardness of the ground, the availability of mechanical excavation machinery, the

⁵⁸Engineer, Lieutenant Colonel O. Shcherbakov, "From Frames and Flexible Covers," *Voennye Znaniia*, No. 3, March 1972, p. 24.

size of the cover and the types of materials used in the construction. For example, a 10-man radiation cover without shored walls, built of unnotched beams, is said to require 70-110 man-hours; a 20-man cover built of concrete slabs may require 200-240 man-hours; a 40-man cover built of wooden beams may need some 270 man-hours; and a 10-man adobe block radiation cover takes 320-350 man-hours to build.⁵⁹

2. Radiation Covers in Adapted Basements, Cellars, and Buildings

Soviet publications devote considerable attention to the adaptation of basements, root and refrigeration cellars, storage sheds and aboveground rooms in existing buildings in small towns, and in rural areas for use as radiation covers. To adapt such spaces for this purpose requires three basic measures: increasing the protection factor, sealing them against radioactive dust, and installing a simple ventilation system.

While unimproved basements in wooden frame buildings provide a radiation protection factor of 6-8, and 20-40 in a brick or stone building, the radiation protection factor can be raised to 100, and even up to 1,000, by the banking of earth against the exposed portion of the external basement walls to a height of not less than 20-30 cm above the basement roof, sealing all external openings with bricks or sandbags, placing a layer of 25-60 cm of earth on the floor above the basement (a new wooden floor can be installed on top of the earth layer), and reinforcing the basement roof with beams or frames.⁶⁰ Additional protection can be provided by placing a layer of 25-40 cm of earth on the attic floor. In single-story brick or stone buildings this can be used in lieu of placing the earth cover on the ground floor above the shelter. The basement covers should have entrances located inside the building and equipped with tight-fitting doors or trap doors. The preparation of such basement radiation covers with space for 10-20 persons is said to require 30-90 man-hours of work.⁶¹ It is noted that such covers in the basement can withstand 1-3 kg/cm² (i.e., 14.2 psi to 42.6 psi) blast overpressure.⁶²

A similar procedure is used to prepare separate standing root, vegetable, or refrigeration cellars for use as radiation covers. These cellars

⁵⁹Ostroukh, *Stroitel'stvo*, pp. 57, 60; Molodykh, et al., *Protivoradiatsionnye*, pp. 30-33; Yegorov, et al., *Grazhdanskaia Oborona*, 2nd edition, p. 212.

⁶⁰Ostroukh, *Stroitel'stvo*, p. 98; A. K. Sudakov, *Zashchita Naseleniia ot Radioaktivnykh Osadkov (Protection of the Population from Radioactive Fallout)* (Moscow: Atomizdat, 1969), p. 34; N. I. Akimov and V. G. Il'in, *Grazhdanskaia Oborona na Obehtakh Sel'sko-Khoziaistvennogo Proizvodstva (Civil Defense and Enterprises of Agricultural Production)* (Moscow: Kolos, 1973), p. 174; Molodykh, et al., *Protivoradiatsionnye*, pp. 11-12.

⁶¹Molodykh, et al., *Protivoradiatsionnye*, pp. 11, 13.

⁶²Iakubovskii, *Grazhdanskaia Oborona*, p. 33.

should be provided with tightly fitting doors, and preferably also a wooden-covered entry, and covered with an additional layer of 65-80 cm of earth. It is also recommended that a wall of brick, stone or adobe can be built outside, opposite the entrance door, and at a distance of about 1.5 meters from it, to shield the entrance from external radiation.⁶³ The width of this wall should be twice that of the door, and the height equal to it. In addition, a curtain should be hung inside the cover, facing the entrance door, as a further protection against the penetration of radioactive dust into the occupied section of the cover.

Soviet publications also mention the possibility of adapting above-ground space in existing buildings for use as radiation covers. It should be noted that this is not recommended for use in large cities and potential target areas for enemy attack, but is to be used only in areas threatened by radioactive fallout. In single-story stone or brick buildings all windows and unnecessary openings should be sealed with bricks, and a layer of 30-40 cm of earth placed over the attic floor. If properly sealed such a space can provide a radiation protection factor of 50-60, and would require some 60-80 man-hours to prepare. Similar measures can be used in single-story buildings built of concrete blocks or adobe blocks. It is also suggested that internal rooms be used for radiation cover in multi-story buildings. In a two-story building with stone or brick walls 50-60 cm thick, the procedure is the same as in a single-story building for adapting a room on the ground floor as a radiation cover, except that the layer of earth would not necessarily be placed on the attic floor, but on the second-story floor, above the radiation cover. In the case of wood-frame or log buildings, it is desirable to raise the protection factor provided by the external walls by adding thickness up to the height of the radiation cover. This can be done by building an additional wall of bricks or stones, or of sandbags held in place by upright beams driven into the ground, or by building wooden retaining walls, some 40-50 cm from the walls of the building and filling the space between with sand or earth. Such a cover is said to provide a radiation protection factor of 100-130, and a 20-meter square protected space in a single-story building requires some 160-200 man-hours to build.⁶⁴

3. *Simple Expedient Radiation Covers*

The simplest type of expedient radiation cover is the slit trench, which can be open, but preferably should be covered. The trench is 1.8-2 meters deep, 1.1-1.6 meters wide at the top, and 0.8 meters wide at the

⁶³Molodykh, *et al.*, *Protivoradiatsionnye*, p. 14.

⁶⁴*Ibid.*, pp. 15-19; Sudakov, *Zashchita*, 2nd edition, pp. 49-51.

bottom. The trench can be built in the form of a zigzag, each rectilinear section being 10 meters long and at a right angle to the next section. Up to 20 persons can occupy each rectilinear section, on the basis of a single row of seats, allowing 0.5 to 0.6 meters of seating space per person.

In hard, dry soil, the sides of the trench need not be shored, and the steepness (ratio of setback to height) can be on the order of 1:8. In loose or wet soil, the steepness of the sides can be on the order of 1:4, and the sides will have to be shored, using a variety of available materials, such as round poles, wooden boards, metal sheets, concrete slabs, mats of woven reeds, branches, etc. If the sides of the trench do not require shoring, the roof can be made of beams or poles, 10-14 cm in diameter, placed across the trench in a shallow cut, so that the top of the beams are even with the surface of the ground and extend 50 cm on either

Cross Section of a Covered Trench
(dimensions are given in centimeters)

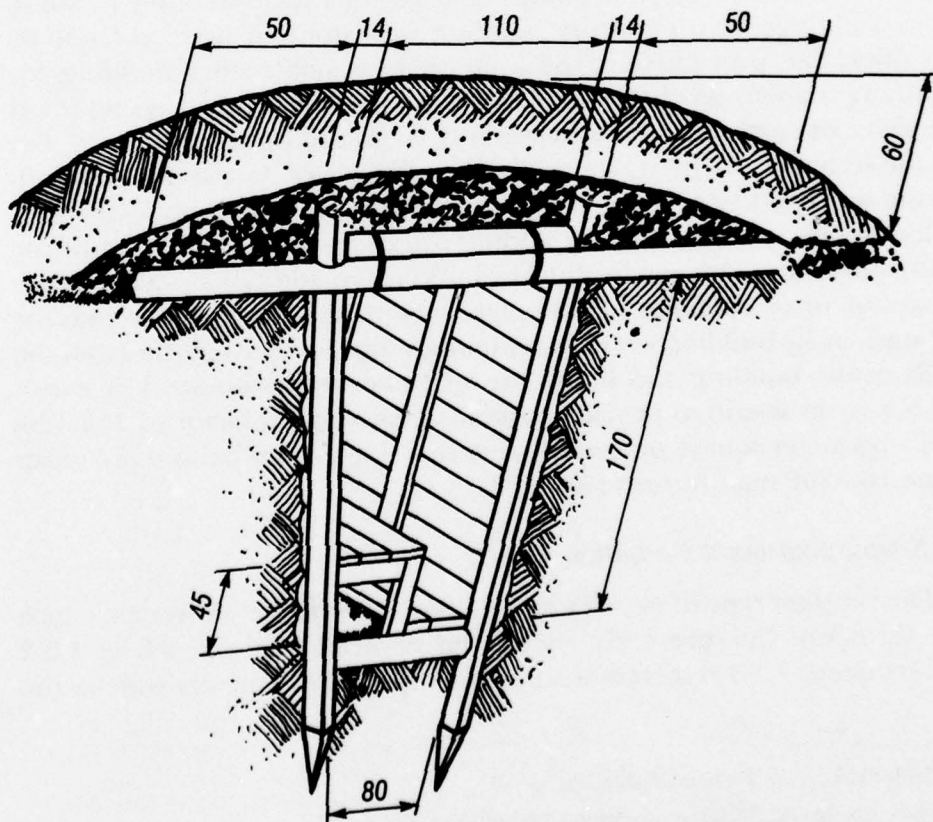

side of the lip of the trench. Waterproofing materials such as rubberoid or polyethylene sheets, woven mats, several layers of canvas, etc., are then placed on the beams, which, in turn, are covered with 60-80 cm of earth. The earth mound is covered with sod and extends beyond the trench and the sides form a slope with an incline no greater than 1:2. Drainage ditches are then dug on either side of the mound. There should be entrances at either end of the trench, placed at right angles to it, either in the form of inclines with steps, or perpendicular shafts with ladders. If time permits, the entrances should be provided with tight-fitting wooden doors. Additional protection against penetration of radioactive fallout into the trench is provided by one or two cloth curtains made of burlap, canvas, or other handy material, such as blankets. In wet soil a drainage ditch filled with sand or gravel is dug along the bottom of the trench and covered with floor boards.

In loose or wet soil which requires shoring of the trench walls, frames are built of upright wooden beams some 10-14 cm in diameter. These are pounded into the ground to a depth of not less than 15 cm. The spaces between the uprights are about 10 cm in diameter and tied to the uprights. Some Soviet publications show spaces of a similar diameter at the bottom of the trench between the uprights, while others show thick boards between the uprights, which also serve as floor boards. The frames are about 0.9 meters apart, and the uprights hold the wall shoring (made of wooden boards, woven mats, or sheet metal) in place. The roof can be built in a manner similar to that of the unshored trench covers, but wooden slabs 10-12 cm thick can also be used instead of round beams or poles. An alternative method is to place a line of logs or beams on either side of the trench and parallel to it, some 40-50 cm from the lip of the trench, and to bury these logs to half their diameter. The roof beams or poles are then placed on top of these logs. All roofs of such covers are waterproofed with a layer of compacted clay and covered with 60-80 cm or more of earth and sod.

The construction of a simple slit-trench radiation cover for ten persons, without shoring of trench walls, is said to require 30-40 man-hours of labor, and such a cover will provide a radiation protection factor of 250-300. If the trench walls are shored, the construction will require 100-130 man-hours and will provide the same radiation protection factor.⁶⁵ If the slit-trench cover lacks tightly-fitting doors, it is recommended that the persons occupying it wear their gas masks and protective clothing

⁶⁵*Ibid.*, pp. 25, 26; Yegorov, et al., *Grazhdanskaia Oborona*, 3rd edition, p. 131 in English translation. Some Soviet publications place the radiation protection factor in slit-trench covers at 40-100. See *Eto Dolzhen Znat' Kazhdyi (Everyone Must Know This)*, 2nd edition (Kishinev: Kartya Moldovenyaske, 1973), p. 36.

during the actual fallout and on windy days as a precaution against the penetration of radioactive dust into the trench.

The construction of simple expedient radiation shelters in winter or in areas with permafrost poses special problems as well as opportunities. Although the digging of trenches becomes more difficult and is slowed down considerably because of the hardness of the ground, it is possible to use snow, snow blocks, and cut blocks of frozen soil for shielding against radiation. Frozen soil, it is noted, equals rock or concrete in hardness, so that the sides of the trenches do not require shoring. Frozen blocks of earth can be used to form the roof over the trench, and further protection is provided by piling 1-2 meters of snow on top of the blocks. These types of covers are said to provide a radiation protection factor of 200 to 400. In addition, small expedient covers can be built in the form of huts, with two gables made of poles, or a conical hut built of poles or dry branches, and covered with a mound of snow some 1.5 to 2 meters thick at the top, and up to 4-5 meters along the sides, which is said to provide a radiation protection factor of 50 to 80.⁶⁶ The construction of covers in winter conditions and in frozen earth is especially important in the USSR, where 47 percent of the land area consists of permafrost, and only 10 percent remains unfrozen in wintertime.

The slit-trench type cover is not intended for prolonged occupancy. It has no bunks, and, at best, only bucket-type toilets, and has no forced-air ventilation system. The covered slit trench uses a gravity flow air ventilation system, and therefore is likely to become unacceptably hot in a short time, except in cold weather. It is recommended, therefore, that, if time permits, the protective, ventilation and other features of the slit trench be improved to the level of the detached radiation covers.

Soviet publications also mention other methods for building expedient simple radiation covers. For example, it is suggested that in potato storage sheds a space between two bins of potatoes can be used to protect people against radiation. Even better protection is provided if another bin is built above the cover space on top of the two side bins. With a 30 cm thick layer of potatoes above the cover space, there will be a radiation protection factor of 40; a 50 cm layer of potatoes will provide a protection factor of 80; and an 80 cm layer, a protection factor of 170.⁶⁷

Semi-underground vegetable storage sheds can be adapted for use as radiation covers by covering the entire structure with a layer of earth 30-80 cm thick.⁶⁸ This will provide a radiation protection factor of 140

⁶⁶Ostroukh, *Stroitel'stvo*, pp. 112-127.

⁶⁷L. M. Gorshkov, *Kak Postroit' Protivoradiatsionnye Ukrytiia na Sele (How to Build Anti-radiation Covers in the Village)* (Moscow: Kolos, 1968), pp. 24-25.

⁶⁸Molodykh, et al., *Protivoradiatsionnye*, pp. 19-20; Gorshkov, *Kak Postroit'*, p. 26; Kotlukov, Lebedeva and Gorelov, *Grazhdanskaia Oborona*, p. 26.

to 6,000. Additional protection can be provided by building a covered entrance to the top of the steps leading to the shed and installing a door at the top of the steps, in addition to a door at the bottom, or by hanging a curtain over the actual entrance to the shed. The amount of work required to prepare such a cover with space for ten persons is said to amount to 20-30 man-hours. Such sheds can be provided with forced-air ventilation and dust filters.

One can also build a lean-to type of cover on the reverse slope of an elevation, using the elevation to form one side of the structure. Upright beams some 12 cm in diameter would be used, the walls constructed of poles or boards, and the roof of a frame of beams 12 cm in diameter, with poles 8 cm in diameter placed crosswise on them. The structure should be covered with compacted clay, 10-20 cm thick, and a 50-60 cm layer of earth. The entrance should be in the form of a sloping trench, at a right angle to the door. For further protection, a cloth curtain should be hung between the door and the actual space prepared for occupancy. Such a structure, with space for 12 to 15 persons, is said to require 150-170 man-hours to build, and provides a radiation protection factor of 150-200.⁶⁹

Although most types of radiation covers are of an expedient type, this does not preclude the construction in peacetime of permanent protective covers in the rural areas. Reports by human sources indicate that basements in new brick, stone, or concrete buildings in the countryside may be increasingly designed and prepared as stand-by radiation covers, and would not require further structural improvements for this purpose in an emergency.

⁶⁹Molodykh, *et al.*, *Protivoradiatsionnye*, pp. 27-28.

CHAPTER THREE

Shelter Filter-Ventilation Systems

"The basic condition for the possibility of an extended stay of humans in a shelter," notes a Soviet publication, "is the maintaining of the required temperature and humidity conditions as well as gas composition of the air in it."⁷⁰ To maintain the appropriate temperature and humidity levels as well as the quality of air in the shelter is recognized as a major problem.

A person releases heat at the rate of 100 kcal/hour (400 Btu/hour), and moisture at the rate of 80 grams per hour. In a shelter he uses up to 24 liters of oxygen per hour and exhales up to 20 liters of carbon dioxide (CO₂). Additional heat and moisture are released by the shelter filter-ventilation equipment and electric lights. It is noted that the percentage of carbon dioxide in the air increases to unacceptable limits more rapidly than the decline of the oxygen, and that the temperature in a shelter rises more rapidly with a simultaneous increase in humidity. Furthermore, the temperature and humidity in the shelters is affected by the outside temperature and humidity of the air. Soviet publications, therefore, recognize that "the greatest difficulty in ventilating shelters is the question of combating excess heat and humidity,"⁷¹ because an air flow sufficient to maintain the quality of the air at a minimum level will not prevent an unacceptable increase in the temperature and humidity within a relatively short time. In principle, the shelter temperature should not exceed 27-29°C (78-84°F), humidity 70-75 percent, oxygen content in the air should be greater than 15 percent, and the CO₂ content should be no more than 1.5-2 percent.⁷²

The amount of outside air needed to maintain habitable conditions in shelters for prolonged occupancy depends on climatic conditions and ranges from 7-20m³ (4.1 cfm-10.6 cfm) per hour per person. The relationship of air temperature to ventilation requirements is reflected in the following table:⁷³

⁷⁰Onufriev and Danilevskii, *Spravochnik*, p. 6.

⁷¹*Ibid.*

⁷²Iakubovskii, *Grazhdanskaia Oborona*, p. 53; Kammerer and Kharkevich, *Ekspluatatsiia Ubezishch*, p. 54; Yegorov, *et al.*, *Grazhdanskaia Oborona*, 2nd edition, p. 78; Gorshkov, *Kak Postroit'*, p. 30; Onufriev and Danilevskii, *Spravochnik*, p. 6; Sudakov, *Zashchita*, p. 38, places the limit at 30°C, 85% humidity, 15-16% oxygen, and 2% CO₂.

⁷³Yegorov, *et al.*, *Grazhdanskaia Oborona*, 2nd edition, p. 195.

Ambient Air Temperature	Volume of Air Per Person Needed Per Hour
Up to 20°C (68°F)	7 m ³ (4.1 cfm)
20-25°C (68-77°F)	10 m ³ (5.8 cfm)
25-30°C (77-86°F)	14 m ³ (8.2 cfm)
Over 30°C (86°F)	20 m ³ (10.6 cfm)

This corresponds roughly also to the four main climatic zones in the Soviet Union.⁷⁴ These climatic zones are: 1. Atlantic, which encompasses most of European Russia, with the exception of the extreme southeast; 2. Northern Continental, which includes most of Siberia; 3. Pacific, including the Soviet Far East; and 4. Southern-Continental, including Central Asia and the southeast portion of European Russia, up to the Volga River.⁷⁵ The temperature in January in most of European Russia, including Moscow, ranges between -20°C to 10°C; and in southern European Russia, -10°C to 0°C; while the July temperature in northern European Russia ranges between 10°C to 15°C; in Central European Russia, including Moscow, 15°C to 20°C; and in southern European Russia, 20°C to 25°C. In order to estimate the ventilation requirements for shelters, they should be calculated on the basis of the mean July temperature and humidity in the given region.⁷⁶

The problem of maintaining the appropriate temperature, humidity and air quality in shelters, however, is complicated by the requirement of protecting the occupants against hostile external conditions which may result from a nuclear or chemical attack. Ventilation systems in shelters in potential target areas for nuclear strikes must not only be capable of removing radioactive dust, but, according to Soviet views, must also be capable of filtering out toxic gases. Furthermore, it may be necessary to seal the shelter against all outside air immediately following an attack, or if the shelter is in an area with large fires or a fire storm, and if the ventilation system uses outside air, it must be cooled before it enters the shelter. The ventilation systems must be able to provide appropriate conditions for long-term shelter occupancy. Outside the target areas the ventilation systems in anti-radiation fallout covers must be able to filter out radioactive dust.

⁷⁴Kammerer and Kharkevich, *Ekspluatatsiia Ubezhischch*, p. 55.

⁷⁵*Bol'shaia Sovetskaia Entsiklopediia, Soiuz Sovetskikh Sotsialisticheskikh Respublik* (Moscow: Sovetskaia Entsiklopediia, 1948), p. 152.

⁷⁶Ostroukh, *Stroitel'stvo*, p. 86.

As was noted, one of the elements in the Soviet classification of shelters is the type of filter-ventilation system used in them. Specifically, the 1977 edition of an authoritative Soviet civil defense manual lists only two general types of filter ventilation systems: factory-made filter-ventilation equipment and simple air filter systems made from handy materials.⁷⁷ Soviet publications, including this manual, however, also mention a third type, which consists of a free air flow or gravity air flow system with simple dust filters for use in expedient radiation covers with a capacity for 10 to 30 persons.⁷⁸

A. Factory-Made Filter-Ventilation Systems

The filter-ventilation system in shelters located in potential target areas for a nuclear strike must be capable of operating in three modes: (a) "pure air ventilation" mode, which only filters out radioactive dust particles from the outside air; (b) "filter-ventilation" mode, which in addition to removing fallout dust also filters out toxic gases and fine radioactive dust from the outside air; and (c) "total isolation" from outside air. In addition, the filter-ventilation system must be protected against blast overpressure. The "pure air ventilation" mode must supply a sufficient volume of filtered air to assure the necessary temperature, humidity and quality of air conditions for long-term shelter occupancy, i.e., 7-20 m³ per hour per person. The "filter-ventilation" and "total isolation" modes must be capable of providing sufficient clean air (defined as not less than 2 m³ per hour per person for shelter occupants at rest, and 5 m³ per hour per person for persons working in civil defense command posts for a number of hours),⁷⁹ to maintain the minimum standard of air quality, while depending on the enclosing structure and the earth to absorb some of the heat built up inside the shelter during this time.

The basic air supply system consists of air intake installations, anti-blast valves, dust filters, absorption filters, heat-absorbent filters, fans, air-expansion chambers, air-flow regulation facilities and exhaust systems. In practice, the ventilation system has one, and preferably two, air intakes. One of these takes advantage of the emergency shelter exit and tunnel. The other will be a separate intake located in a small aboveground concrete block or head. Both types of intakes will be provided with anti-

⁷⁷Yegorov, *et al.*, *Grazhdanskaia Oborona*, 3rd edition, p. 104 in English translation.

⁷⁸*Ibid.*, p. 126-127; Molodykh, *et al.*, *Protivoradiatsionnye*, pp. 10-11; *Eto Dolzhen Znat' Kazhdyi*, p. 14; Kotlukov, Lebedeva and Gorelov, *Grazhdanskaia Oborona*, p. 25; Sudakov, *Zashchita*, p. 53; Ostroukh, *Stroitel'stvo*, p. 105.

⁷⁹Sudakov, *Zashchita*, p. 38; Yegorov, *et al.*, *Grazhdanskaia Oborona*, 3rd edition, p. 109 in English translation; Ostroukh, *Stroitel'stvo*, pp. 86-88; Gorshkov, *Kak Postroit'*, p. 30.

blast valves or screens. There are several types of such valves and screens, such as floating cutoff valves with a metal deflector (Soviet designation: KOP or DZU),⁸⁰ or a metal laminated baffle system in a box arrangement (Soviet designation: MZS, which is 25 × 29 × 20 cm, or a model ZSU of a simpler design which is 78 × 78 × 19 cm.)⁸¹ Earlier, types of anti-blast devices consisted of boxes of 60 × 60 cm or 70 × 80 cm of gravel (20-40 mm in diameter) placed on a metal or wooden grill.⁸² When it was used directly in the wall of the emergency exit, the bottom grill could be removed and the gravel dumped so as to open the passage to the surface exit.

In the "pure air ventilation" mode there is a dust filter consisting of a series of metal mesh screens saturated with spindle oil, mounted in a box assembly 51×51×8 cm (Soviet designation: VNIISTO). The capacity of a filter pack is 1,000 to 1,100 m³/hour, with an aerodynamic drag of 3 to 8 mm (on a water-pressure reading set). This filter must be located outside the shelter area.

To use the ventilation system in the "filter-ventilation" mode, especially in shelters located in fire-prone areas, it should have carbon monoxide filters and heat exchanges on the ventilation line before the air reaches the dust filters. To remove the carbon monoxide, use is made of a filter with hopcalite cartridges (Soviet designation: FMSH).⁸³ The filter should not be more than 5 meters from the air intake and located in front of the heat-transfer unit. Unlike the FMSH filter, the heat-transfer unit is not manufactured but built on the spot. It consists of a layer of 0.7 to 1 meter of gravel or other heat absorbent material, the requirement being calculated on the basis of 0.7 m³ of gravel for every 100 m³ per hour of air delivered through it for shelters in fire-prone areas and 2 m³ of gravel for 100 m³/hour of air delivered for shelters in potential areas of fire storms or massive fires.⁸⁴ The gravel is placed in a chamber built of brick or reinforced concrete, about 2×3×2 meters, on top of a grating of 12 cm-thick reinforced concrete. A 40 cm deep space is left below the grating and above the gravel for the delivery of hot air and the removal

⁸⁰Yegorov, *et al.*, *Grazhdanskaia Oborona*, 2nd edition, p. 193; Kammerer and Kharkevich, *Ekspluatatsiia Ubezishch*, p. 19; Ostroukh, *Stroitel'stvo*, p. 89.

⁸¹Kammerer and Kharkevich, *Ekspluatatsiia Ubezishch*, pp. 19-20; Ostroukh, *Stroitel'stvo*, p. 88.

⁸²Gouré, *Civil Defense in the Soviet Union*, pp. 90, 101-102; Kammerer and Kharkevich, *Ekspluatatsiia Ubezishch*, p. 141.

⁸³Onufriev and Danilevskii, *Spravochnik*, p. 8; Kammerer and Kharkevich, *Ekspluatatsiia Ubezishch*, p. 15; Yegorov, *et al.*, *Grazhdanskaia Oborona*, 2nd edition, p. 192.

⁸⁴Onufriev and Danilevskii, *Spravochnik*, p. 5; Yegorov, *et al.*, *Grazhdanskaia Oborona*, 2nd edition, p. 190.

Diagram of Shelter Ventilation System

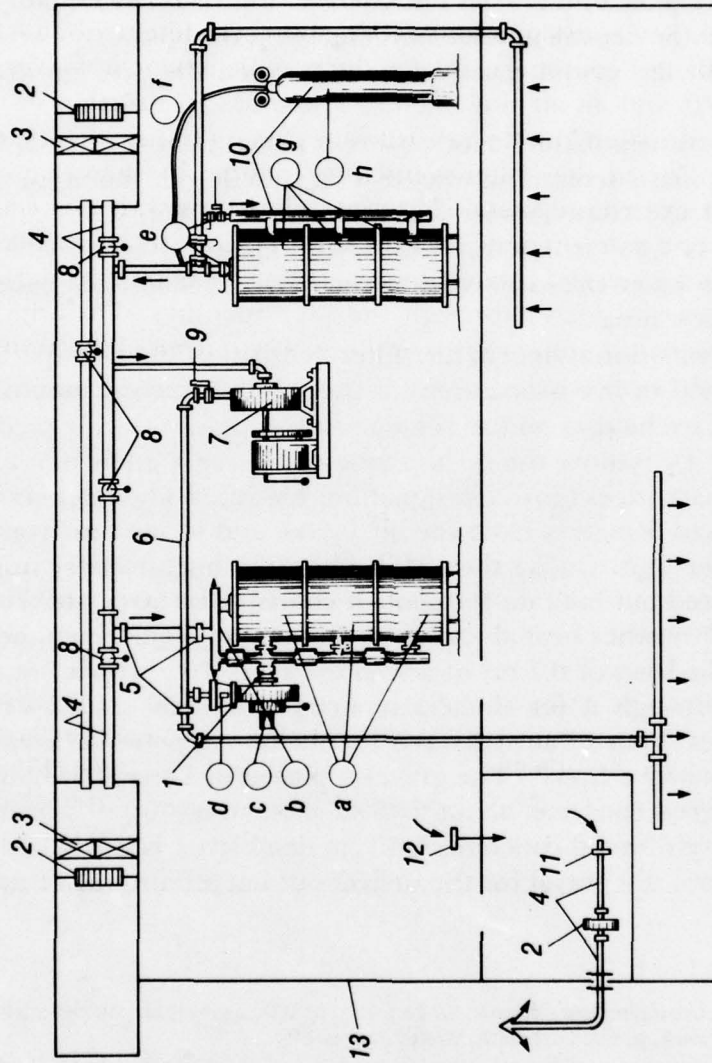

(1) Filter-ventilation unit FVA-49 (a - chemical filter-absorbers FP-100-u; b - double hermetic valve; c - electric fan ERV-49 for operation in filter-ventilation mode; d - air flow indicator); (2) anti-blast device; (3) dust filter; (4) air intake pipes; (5) connecting couplings; (6) air distributor ducts; (7) electric-manual fans for operation in pure air ventilation mode; (8) hermetically sealing valve; (9) air flow indicator; (10) air regeneration unit (e - damper valves; f - oxygen line; g - regeneration cartridges; h - compressed oxygen cylinders); (11) hermetic regulatory valve; (12) overpressure valve (KID); (13) sealed shelter area.

of cooled air, with the direction of the air flow being from the bottom up.⁸⁵ Alternatively, if the shelter has its own artesian well, water can be used to cool the air in the intake pipe.⁸⁶ Another method is to cool the interior shelter air by recirculating it through a water-cooled conditioning system.⁸⁷

The filter-ventilation unit is located in a special enclosed space inside the shelter. The basic unit (Soviet designation: FVA) consists of an electric-manual fan (Soviet designation: ERV), absorbent filters, double hermetic valves, flange couplings, intake ducts with hermetic valves, air distributor ducts and an air flow meter. The unit can function in both the "pure air ventilation" mode, i.e., without passing the air through the absorber filters, or in the "filter-ventilation" mode, by doing so. The absorber filters are round metal cannisters or drums with two central openings and one side opening. Each cannister consists of cardboard smoke filters and a layer of catalyst charcoal. The air enters through the central openings and leaves through the side openings. The absorber filters are installed in columns of two or three. The output of the absorber filter depends upon its size.

Basic Characteristics of Manufactured Absorber Filters⁸⁸

Make of Absorber Filter	Dates of Start of Production	Weight in kg	Dimensions in cm Diameter Height	Drag mm H ₂ O	Output m ³ /hour
FP-100	1950-1956	60-70	55 50.7	40-50	100 (55 cfm)
FP-100u	1956	56-66	54-55 50.7	40-50	100 (55 cfm)
FP-300	1969	65-75	58 61.0	85	300 (165 cfm)
FP-200	1974, as replacement for FP-100u	38	44.4 38.0	—	100 (55 cfm)

⁸⁵Onufriev and Danilevskii, *Spravochnik*, p. 9; Kammerer and Kharkevich, *Ekspluatatsiia Ubezhishch*, pp. 16-17.

⁸⁶Kammerer and Kharkevich, *Ekspluatatsiia Ubezhishch*, p. 16.

⁸⁷Onufriev and Danilevskii, *Spravochnik*, p. 7.

⁸⁸Yegorov, *et al.*, *Grazhdanskaia Oborona*, 3rd edition, p. 111 in English translation; Sudakov, *Zashchita*, p. 40. An FP-200-57 and FP-200-59 are said to have also been produced starting in 1957, and may have an output of 200 m³/hour, as reported in Sudakov, *Zashchita*, p. 31.

When it is necessary to supply a large volume of air "the absorber filters are arranged with batteries."⁸⁹

Soviet publications do not describe the large-capacity filter-ventilation units which are used in large capacity shelters. Presumably, these are the units which use the FP-300 type absorber filters. It is said, however, that such shelters (with space for more than 450 persons), will have independent protected electric power sources (i.e., diesel-electric generators), and that they will use centrifugal fans with electric drives.⁹⁰ The filter-ventilation units most often described and illustrated in Soviet publications are the FVA-49 model, using FP-100 absorber filters, which are said to be intended for use in small and medium-capacity shelters. In view of the limited output of this unit, said to be 400-450 m³/hour (220 cfm-247 cfm) when operating in a "pure air ventilation" mode, and 300 m³/hour (165 cfm)⁹¹ when operating in the "filter-ventilation" mode, the output in the first mode is "usually" supplemented by an additional electric fan, which pulls in filtered air from the emergency shelter exit air intake, while the filter-ventilation unit uses the alternate air intake.⁹²

For shelters located in areas of potential mass fires, it is expected, in the event of a nuclear attack, that the high air temperatures and severe deterioration of the quality of the air will force the temporary cessation of the intake of outside air for ventilation purposes. In this event, the air in the shelter will have to be regenerated. The regeneration of interior shelter air can be accomplished by means of special air regeneration cartridges (Soviet designation: RP-100), containing chemical absorbers of carbon dioxide such as calcium hydroxide (Ca(OH)₂). The cartridges are similar in appearance to the FP-100 absorber filters and are also mounted in columns of two or three and connected to an electric-manual fan, like that of the FVA unit. To make up for the progressive decline of oxygen in the shelter air, it is replenished from compressed oxygen cylinders (150 atmosphere) which are connected to the ventilation system through a reduction valve. Alternatively, use is made of a connection-type air regeneration unit (Soviet designation: RUKT) which consists of a metal housing in which cartridges with a potassium peroxide compound are inserted. One kilogram of this compound can release as much as 250 liters of oxygen and absorb 150 liters of carbon dioxide.⁹³ Since the

⁸⁹Yegorov, *et al.*, *Grazhdanskaia Oborona*, 3rd edition, p. 111, in English translation.

⁹⁰*Ibid.*, 2nd edition, p. 191.

⁹¹*Ibid.*, 3rd edition, p. 112 in English translation.

⁹²Kammerer and Kharkevich, *Ekspluatatsiia Ubezhishch*, p. 58; Ostroukh, "There, Where the Conditions Exist," *Voennye Znaniia*, No. 12, December 1972, p. 31.

⁹³Yegorov, *et al.*, *Grazhdanskaia Oborona*, 2nd edition, p. 192.

air is drawn through the unit by thermal pressure, there is no requirement to use forced draft air circulation in its operation. The number of convection-type air regeneration units in a shelter is calculated as a function of regeneration time, number of occupants, and the unit's capacity, taking into account a rate of consumption of 25 liters of oxygen per person per hour, and the exhaling of 20 liters of carbon dioxide per person per hour.

In order to guard against any seepage of smoke or toxic gases into the shelter, the air pressure inside it is kept a little higher than the outside air pressure. This is achieved by supplying air through the filter-ventilation unit at a "rate one-third of the volume of the enclosed space [i.e., shelter] per hour."⁹⁴ The amount of excess pressure cited in Soviet publications varies, some placing it at 1.5-2 mm H₂O, others higher (up to 7mm H₂O). The air pressure in the shelter is monitored by means of a pressure gauge.⁹⁵

The air exhaust system is usually located in the toilet area of the shelter. It includes air exhaust ducts, sealing valves, regulating valves, and anti-blast devices. In large capacity shelters the proper air flow is assured by electric exhaust fans.⁹⁶ The exhaust ducts are protected by an overpressure valve (Soviet designation: OPU), consisting of a metal disk with rubber packing, which is pressed against its metal housing by the blast wave, thereby sealing the exhaust ducts.⁹⁷ Its use is recommended over simple filter-ventilation systems in expedient shelters with a capacity of 100-150 persons, even though the equipment costs on the average of 35 percent more than the latter. (For example, in a shelter with a capacity of 100 persons, it costs 4.5 rubles per person vs. 1.5 rubles per person for simple filter-ventilation systems.)⁹⁸ Of course the shelter must be provided with electric power.

B. Simple Filter-Ventilation Systems

The simple filter-ventilation system is used in expedient detached shelters and radiation covers. As distinct from the manufactured filter-ven-

⁹⁴*Ibid.*, p. 193.

⁹⁵*Ibid.*; Kammerer and Kharkevich, *Ekspluatatsiia Ubezhihch*, p. 75; Iakubovskii, *Grazhdanskaia Oborona*, p. 53; Onufriev and Danilevskii, *Spravochnik*, p. 13; F. G. Krotkov, ed., *Meditsinskaia Sluzhba Grazhdanskoi Oborony (The Civil Defense Medical Service)* (Moscow: Meditsina, 1975), translated in JPRS, Translations on USSR Military Affairs, No. 1141, May 9, 1975, p. 19.

⁹⁶Yegorov, *et al.*, *Grazhdanskaia Oborona*, 2nd edition, p. 193; Sudakov, *Zashchita*, p. 44.

⁹⁷Yegorov, *et al.*, *Grazhdanskaia Oborona*, 2nd edition, p. 145.

⁹⁸Ostroukh, "There, Where Conditions Exist," p. 31.

tilation system, the filters are handmade, using easily obtainable materials, and a variety of simple non-electric fans is used.

The simple filter-ventilation system uses two external air intakes: one through the external filter for removal of smoke and toxic materials when operating in the "filter-ventilation" mode, and one through a simple dust filter when operating in the "pure air ventilation" mode. The first is a sand-gravel, slag or crushed shell filter. It is placed in an excavation in the ground some 4-6 meters from the shelter. In the case of a detached shelter built from prefabricated reinforced concrete units, the filter will also be a concrete duct with one opening even with the ground. Otherwise it is built as a square or circular excavation in the ground with sloping sides. For example, if the top area is 3.2×3.2 meters, the bottom is 1.6×1.6 meters, and the height about 1.4 meters.⁹⁹ A metal or wood log grill is placed at the bottom; over that goes a 10 cm-thick layer of 25-30 mm-diameter gravel, then a 5-6 cm layer of 5-10 mm-diameter gravel, and then a 1-meter-thick layer of sand (0.5-3 mm-diameter), or 0.75 meters of slag. The sides of the filter pit are waterproofed and the filter is covered with a gabled roof made of wooden boards covered with tarpaper. The construction of such a filter with a surface area of 3 m² requires 20-30 man-hours.¹⁰⁰

The surface area of the filter depends on the number of shelter occupants, taking into account that 1 m² of sand filters 30 m³ of air per hour, and 1 m² of slag, 60 m³ of air per hour. Therefore, a filter surface of not less than 7 m² of sand or 4 m² of slag is needed for a shelter with a capacity for 100 persons,¹⁰¹ or 0.7 m² of sand and 0.35 m² of slag for a shelter with a capacity for 10 persons.¹⁰²

For ventilation in the "pure air" mode, fabric dust filters are used, utilizing such materials as burlap, linen, serge, satin, flannel, coarse calico, etc., or filters with a 15 cm-thick layer of sand or slag or a 50 cm-thick layer of straw.¹⁰³ Use can also be made of oil filters in wooden frames. In calculating the required area of fabric filter, account is taken of the fact that not more than 75 m³ per hour of air can pass through a 1 m² thickness of them. Thus a shelter with a capacity for 80 persons, requiring

⁹⁹Molodykh, *et al.*, *Protivoradiatsionnye*, p. 21; Yegorov, *et al.*, *Grazhdanskaia Oborona*, 2nd edition, p. 201.

¹⁰⁰Molodykh, *et al.*, *Protivoradiatsionnye*, p. 21.

¹⁰¹Ostroukh, *Stroitel'stvo*, p. 91; Yegorov, *et al.*, *Grazhdanskaia Oborona*, 2nd edition, p. 202.

¹⁰²Ostroukh, "With Simplified Equipment," *Voennye Znaniia*, No. 2, February 1970, p. 23; Molodykh, *et al.*, *Protivoradiatsionnye*, p. 21, states that a 1 m² surface in a sand-gravel filter is the norm for 10-15 persons.

¹⁰³Ostroukh, *Stroitel'stvo*, p. 93.

Schematic Diagram of Simple Shelter Ventilation System

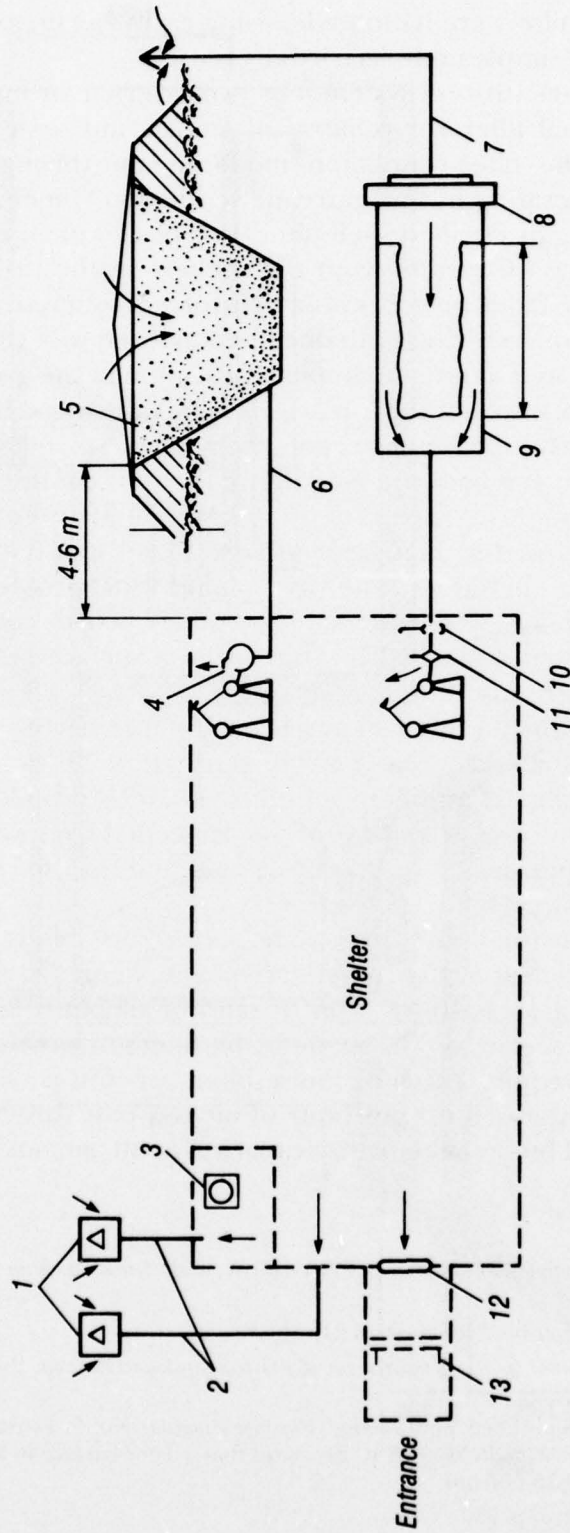

(1) ZU or DZU protective devices or with protection of ZSU-M sections and with protective baffle plates; (2) exhaust ducts; (3) toilet (with cesspit and exhaust duct from it); (4) TSV-1 centrifugal blower with bicycle drive (for filter-ventilation mode); (5) sand (slag) filter; (6) air intake duct for filter-ventilation mode; (7) air intake for pure ventilation mode; (8) ZSU-M protective section; (9) cloth dust filter; (10) slide valve; (11) axial blower with bicycle drive or MV-1 manual drive (for pure mode); (12) airtight door with valve for recirculation of air; (13) protective door with airtight valve.

Simple Air Filter System

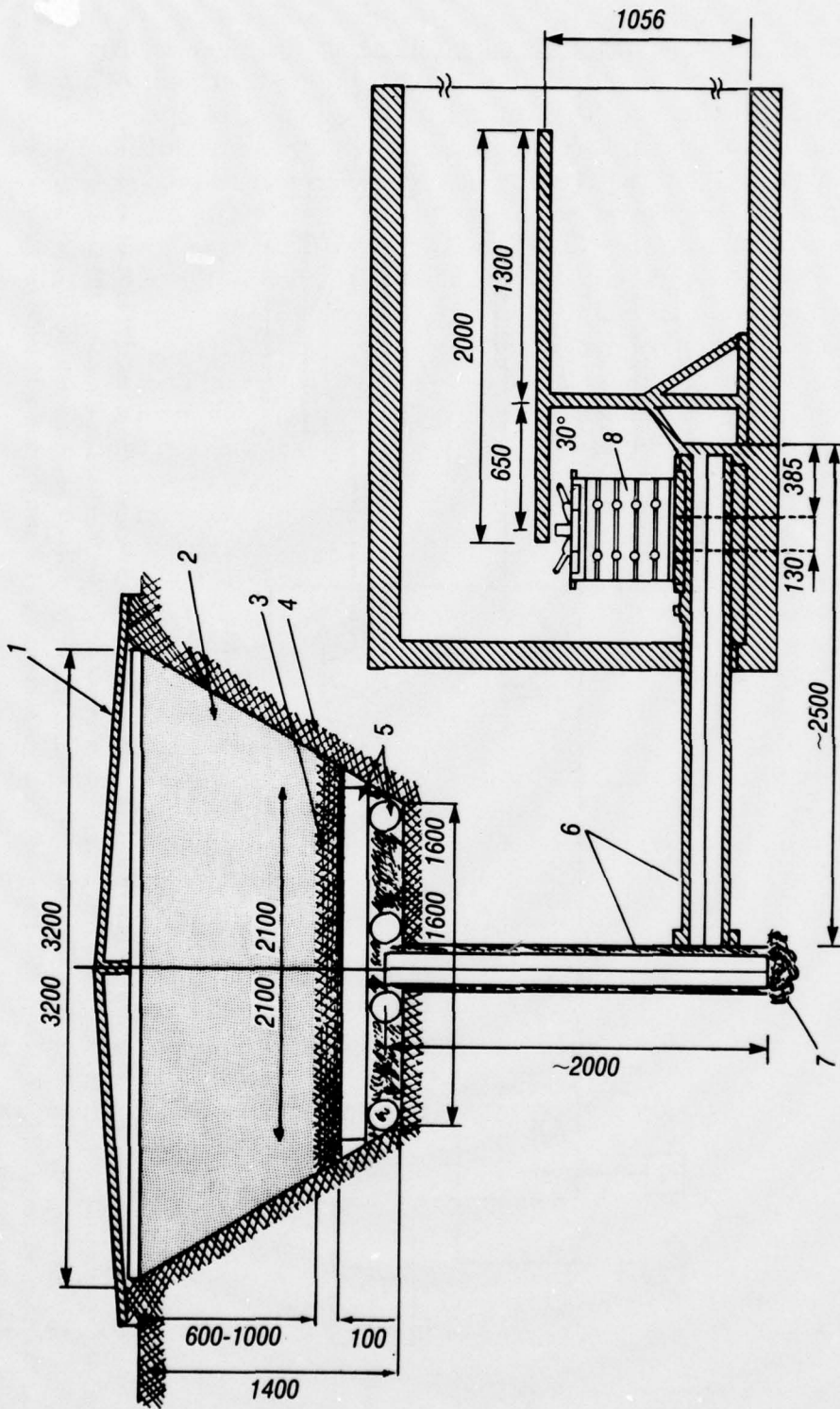

(1) Cover for protecting the filter from atmospheric fallout; (2) coarse sand and coal slag; (3) fine gravel; (4) coarse gravel; (5) beam of 15 to 16 cm diameter; (6) duct; (7) drainage; (8) bellows.
(All dimensions given in millimeters.)

10 m³ per hour per person of air, will need a fabric filter with a surface of 10 m².¹⁰⁴ A one meter square sand or slag dust filter will pass 100 m³ per hour of air, and a straw filter will pass 150 m³ per hour of air.

Unlike the filter for the "filter-ventilation" mode of operation, which acts as its own blast wave dampener, the "pure air ventilation" system requires anti-blast deflector devices to protect the air intakes which are normally 1-3 m above the surface of the ground. Use can be made of either manufactured devices (DZU) or simple devices (Soviet designation: ZU, ZSU-M). Anti-blast devices are also installed in the exhaust ducts. Furthermore, a simple slide valve with flexible connecting sleeves is installed on the intake duct inside the shelter, ahead of the fan.¹⁰⁵

Several types of simple fans or blowers can be used to operate the system. The simplest ones are powered by bicycle or manual drives or bellows. A centrifugal fan attached to a stationary bicycle, which is used to drive it, can supply 200-300 m³ of air per hour when operating in the "pure air ventilation" mode. Bellows can supply approximately 150 m³ of air per hour. If electric power is available an electric axial blower (Soviet designation: ROV) with a capacity of 1,500-3,000 m³ of air per hour can be used.¹⁰⁶ One hand-cranked centrifugal fan can be used for 50 persons, and a bicycle-driven fan or bellows can be used for 70-80 persons.¹⁰⁷ In large-capacity shelters it is necessary to use several ventilation systems.

The ducts for expedient shelters can be built of a variety of handy materials such as clay, steel or iron, concrete or asbestos cement, pipes, wooden boards or bricks. Except for the heads of the air intakes the ducts will be underground and will enter the shelter near the floor on the intake side while the exhaust ducts will leave the shelter near the ceiling.¹⁰⁸

It is noted that for shelters with a capacity of less than 50 persons located in the northern or central areas of the USSR it is more economical to omit the separate "pure air ventilation" system and to rely entirely on the "filter-ventilation" mode, provided that the ventilation system can deliver 4-6 m³ of filtered air per hour per person.¹⁰⁹ In the case of radiation covers outside potential target areas for nuclear strikes, the

¹⁰⁴*Ibid.*

¹⁰⁵*Ibid.*, p. 90.

¹⁰⁶*Ibid.*, pp. 89-90, 91-92; Yegorov, *et al.*, *Grazhdanskaia Oborona*, 2nd edition, pp. 202-204; Ostroukh, "With Simplified Equipment," p. 23.

¹⁰⁷Ostroukh, "With Simplified Equipment," p. 23; Yegorov, *et al.*, *Grazhdanskaia Oborona*, 2nd edition, p. 204.

¹⁰⁸Ostroukh, *Stroitel'stvo*, pp. 92-93.

¹⁰⁹*Ibid.*, p. 92.

ventilation system uses only the "pure air ventilation" mode. Expedient shelters for 80-100 persons in likely target areas, however, may be provided with air regeneration units using ERV-49 type electric-manual fans and compressed oxygen cylinders.¹¹⁰

C. Natural or Gravity-Flow Ventilation

Natural, i.e., not forced, ventilation can be used in expedient radiation covers with a capacity of less than 40 persons and intended for relatively short occupancy. Such a system can supply 3-6 m³ of air per hour, the air having been first passed through a fabric dust filter. The volume of air flow is a function of wind velocity, temperature inside the shelter, the cross section of the intake and exhaust ducts, and their height.

Soviet publications describe several variations of natural air ventilation systems. For example, in basements and cellars adapted as radiation covers an intake duct is built of tight-fitting boards with the top protected by a gabled roof. The air intake duct can be placed inside the room above the basement or outside. The top is up to 1-2 m above ground surface. In addition to the opening at the top of the duct, there is a stop for a dust filter below it in the form of gauze stretched over a frame. The intake duct may form several right angle turns in entering the radiation cover. The bottom of the air intake duct should be 0.5 m above the floor. The portion inside the cover is equipped with a tightly fitting baffle. The bottom of the duct may be open or the duct may have openings on the side below the baffle, and the bottom of the duct is closed to form a pocket to catch the dust which penetrates the filter.¹¹¹ The opening of the exhaust duct in the radiation cover should be 1.5-2 meters above the air intake, near the ceiling. It is also equipped with a baffle. The top of the exhaust duct outside the cover should be 2-3.5 m above the surface of the ground and higher than the top of the air intake.¹¹² It is also possible to use the chimney as an air exhaust.

An alternate system in detached expedient radiation covers is to use the right angle entry of the cover as an air intake and to provide an exhaust duct with a right angle turn and a baffle at the other end of the cover. The incoming air passes through two fabric curtains hung in the vestibule of the cover, and it is also possible to install filters with straw above the entrance to the cover.¹¹³

¹¹⁰*Ibid.*, p. 94.

¹¹¹Molodykh, *et al.*, *Protivoradiatsionnye*, pp. 11-12; Yegorov, *et al.*, *Grazhdanskaia Oborona*, 3rd edition, pp. 126-127.

¹¹²Ostroukh, *Stroitel'stvo*, p. 20; Molodykh, *et al.*, *Protivoradiatsionnye*, p. 12; Yegorov, *et al.*, *Grazhdanskaia Oborona*, 3rd edition, p. 127.

¹¹³Gorshkov, *Kak Postroit'*, p. 31; Ostroukh, *Stroitel'stvo*, pp. 94-95.

CHAPTER FOUR

Shelter Habitability

A. Space, Air Supply and Temperature Control

The possible duration for occupancy of shelters and fallout covers depends, first of all, on the ability of the ventilation system to maintain tolerable levels of air quality, temperature and humidity, and second, on the availability of water, food and toilet facilities. In the case of permanent blast shelters, the rest of the shelter equipment serves to seal the shelter, to operate the ventilation and sewage system, to provide comfort and information for the occupants, and to deal with various emergencies. Specifically, this includes fireproof, hermetically-sealing metal doors, electric power, benches and cots, telephones, radios, receivers, remote radiation reading equipment and fire-fighting equipment, digging tools, medical supplies, stand-by lanterns and candles, decontamination agents, and a reserve of kneaded clay, wire and burlap to patch cracks.

In terms of occupancy, Soviet blast shelters appear to be crowded. The minimum floor space per person is 0.5 m^2 , with an allocation of $0.45 \times 0.45 \text{ m}$ of seating space per person. Space for lying down is calculated on the basis of 0.55 or $0.65 \times 1.8 \text{ m}$ per person, with sufficient space for 20 percent of the occupants. The aisles between opposing rows of seats are $0.70 - 1.95 \text{ m}$ wide, and the main aisles are on the order of $1.2 - 2 \text{ m}$ wide.¹¹⁴ Since the height of the shelter should be not less than 2.2 m , there should be about $1.3 - 1.8 \text{ m}^3$ of space per person, or on the average, 1.5 m^3 per person.¹¹⁵ As was mentioned above, Soviet standards also provide a minimum volume of filtered air of $2 \text{ m}^3/\text{hour}$ (1.1 cfm) per person.

Soviet manuals recognize, however, that these minimum standards for space and ventilation represent merely a base line, and in practice they must be adjusted to take account of ambient air temperatures, humidity, and the capacity of the ventilation equipment. Specifically, it is recognized that, while a volume of $2 \text{ m}^3/\text{hour}$ per person of filtered air may suffice to sustain the quality of air in terms of oxygen content and tolerable limits of CO_2 concentration, it will not be capable of removing the build-up of heat and humidity generated by the shelter occupants. Consequently, how long the occupants would be able to tolerate conditions in

¹¹⁴Titov, *et al.*, *Grazhdanskaia Oborona*, p. 34; Ostroukh, *Stroitel'stvo*, p. 11.

¹¹⁵*Ibid.*; Kammerer and Kharkevich, *Ekspluatatsiia Ubezhisich*, p. 56.

the shelter would depend on the ambient air temperature and the floor space per occupant, as well as the surface area per person of the enclosing structure and its capacity to absorb heat. The literature states that under average conditions (presumably of low or medium ambient temperature) and an air supply of 2 m³/hour per person, the limit of tolerable air temperature and humidity in the shelter will be reached in 10-12 hours.¹¹⁶ With the ventilation system closed down and 2 m³ of air volume per person, the lower limit of permissible concentration of CO₂ will be reached in 3.5-4 hours.¹¹⁷ Therefore, it will not be possible for the occupants to remain in the shelter under such conditions for more than 4-6 hours.¹¹⁸ It is anticipated, however, that under most circumstances where the filter-ventilation system is closed down or while generating only a minimum of 2 m³/hour of filtered air per person (i.e., operating in the filter-ventilation mode), this will be necessary only for a relatively short time.

Soviet standard operational procedures provide that when the shelter is opened for occupancy, the filter-ventilation system is also started, operating in the pure air mode. During a nuclear detonation or before it, the filter-ventilation system is closed down for approximately one hour or, if conditions require it, up to five hours, until the immediate radioactive fallout settles.¹¹⁹ Then if there are no major fires or toxic gases in the area, the ventilation system reverts to the pure air ventilation mode and removes the excess heat which has built up in the shelter under the previous ventilation condition.¹²⁰ In the case of persons in fallout covers farther away from the nuclear detonation, they should anticipate a duration of radioactive fallout of 2 to 5 hours during which time they may have to close down the ventilation system. Soviet publications indicate, therefore, that under average external temperature conditions and minimum standard space per occupant, it will be safe for the shelter occupants to close down the ventilation system for about three hours and to supply a minimum of 2 m³/hour per person of air which has been purified of smoke, carbon monoxide and other toxic gases, for up to 12 hours (i.e., up to when the interior temperature reaches 29-30° C or 84-88° F). Although the basic ventilation norm is set

¹¹⁶Kammerer and Kharkevich, *Ekspluatatsiia Ubezhihshch*, pp. 55, 56; Sudakov, *Zashchita*, p. 38.

¹¹⁷Iakubovskii, *Grazhdanskaia Oborona*, p. 33; Kotlukov, Lebedeva and Gorelov, *Grazhdanskaia Oborona*, p. 25.

¹¹⁸Iakubovskii, *Grazhdanskaia Oborona*, p. 33.

¹¹⁹*Ibid.*, p. 32; Kotlukov, Lebedeva and Gorelov, *Grazhdanskaia Oborona*, p. 24.

¹²⁰Onufriev and Danilevskii, *Spravochnik*, p. 7.

at 2 m³/hour per person, it is noted that in "many cases, taking into account the insufficiency of the absorption of excess heat by the [enclosing] construction materials, the possibility of a poor seal, and the need to maintain an excess pressure, the norm per person is raised to 3-4 m³/hour per person, especially in the southern areas."¹²¹ Naturally, the duration of shelter occupancy under conditions of a closed-down external air intake can be increased if the shelter is provided with air regeneration equipment and reserves of compressed oxygen, and also if the shelter air is cooled.

Since the most difficult problem in shelter habitability is recognized as being the maintenance of tolerable temperature-humidity levels, Soviet publications indicate that this may not be feasible under conditions of minimum standards of 0.5 m² floor space per shelter occupant. Increasing floor space and structural area per occupant will be necessary in areas of high ambient air temperatures, or in shelters where the ventilation system cannot deliver the maximum desirable volume of air. Thus, according to Soviet publications, the following amounts of floor space per person will be required for long-term occupancy as a function of volume of air supplied by the ventilation system and the outside air temperature:

TABLE 1
Floor Space per Person as a Function of
Ventilation and Ambient Temperature¹²²
in Aboveground Shelters

Volume of air supply in m ³ /hour per person	Temperature of Outside Air in °C					26° (and more for regions with relative humidity over 50% less than 50%)	
	5 - 10	11 - 15	16 - 20	21 - 25	26°		
	Minimum Floor Space per Person in m ² /Person						
2	0.9	1.2	—	—	—	—	—
4	0.8	1.0	1.4	—	—	—	—
6	0.7	0.9	1.3	2.5	—	—	—
8	0.6	0.7	1.1	2.3	—	—	1.9
10	0.5	0.6	1.0	2.2	—	—	1.8
12	0.5	0.5	0.8	2.1	2.5	—	1.6

¹²¹Ostroukh, "There, Where Conditions Exist," p. 31.

¹²²Ostroukh, *Stroitel'stvo*, p. 106.

It is evident from this chart that the minimum standard space of 0.5 m² per person is only permissible under certain levels of outside air temperature and volumes of ventilation or, in the case of higher ambient temperatures, if the volume of air supplied by the ventilation system is on the order of 14-20 m³/hour per person. Of course, if the temperatures are lower, especially in the winter when they are below 0° C, the capacity of occupancy of the shelter can be increased 1.5 to 2 times at the expense of the floor space per person.¹²³

In calculating the permissible floor space per person and the required volume of ventilation, account is also taken of the amount of surface of the enclosing structure and its heat absorption capacity, noting that in any event this surface, at the start, will be at least 2 - 4° C cooler than the outside air temperature. Thus, in the "central region" of the USSR shelters with a volume of ventilation of 2 m³/hour per person will have to provide the following area of structural surface per person, depending on the materials used in the construction.

TABLE 2
Structural Surface per Person Required
as a Function of Materials¹²⁴

Materials		Area of structure per person in m ²
Walls	Roof	
Reinforced concrete	Reinforced concrete	1.5
	Metal	1.5
	Wood	1.5
Earth-filled bags	Reinforced concrete	1.5
	Metal	1.9
	Wood	2.2
Wood	Reinforced concrete	1.8
	Metal	2.5
	Wood	2.8
Brick	Reinforced concrete	1.6
	Metal	—
	Wood	1.7

¹²³*Ibid.*, p. 107.

¹²⁴*Ibid.*, p. 10.

Thus, taking account of the heat absorption capacity of the materials in the enclosing shelter structure, the following table reflects the effect on required floor space per person for various volumes of ventilation. (Unfortunately, the table does not indicate what surface area of the enclosing structure is assumed per person.)

TABLE 3
Floor Space per Person as a Function of
Initial Temperature and Structural Materials
in Underground Shelters¹²⁵

Volume of air supply in m ³ /hour per person	Materials of Enclosing Structure															
	Wood				Brick				Reinforced concrete slabs, Natural stone				Cast reinforced concrete			
	Initial Temperature of Surface of Enclosing Structure in °C															
	10	15	20	25	10	15	20	25	10	15	20	25	10	15	20	25
Minimum Floor Space per Person in m ² /Person																
2	1.0	1.4	2.3	—	0.8	1.0	1.7	—	0.7	0.8	1.4	—	0.6	0.7	1.2	—
4	0.7	1.1	2.0	—	0.5	0.7	1.3	—	0.5	0.6	1.1	—	0.5	0.5	1.2	—
6	0.5	0.7	1.3	3.7	—	0.5	1.0	2.2	—	0.5	0.8	2.0	—	—	0.7	1.8
8	—	—	0.9	3.0	—	—	0.7	1.9	—	—	0.5	1.7	—	—	0.5	1.5
10	—	—	0.5	2.0	—	—	0.5	1.6	—	—	—	1.4	—	—	—	1.1
12	—	—	—	1.3	—	—	—	1.2	—	—	—	1.0	—	—	—	0.8
14	—	—	—	0.9	—	—	—	0.7	—	—	—	0.6	—	—	—	0.5

Obviously, the better the structural materials are able to dissipate the heat, the less minimal floor space and volume of ventilation per shelter occupant will be required. As the table shows, the best material for this purpose is concrete.¹²⁶ Even so, it is worth noting that, under conditions of a minimal air supply of 2 m³/hour per person, long-term shelter occupancy is impossible for the indicated range of temperatures (50-77° F) if the occupants are limited to 0.5 m² of floor space per person. Only if the ambient temperatures are well below 50° F may such crowding be permissible without resulting in excessive heat in the shelter. Table 3 confirms, therefore, that the Soviets envisage providing a minimum of 2 m³/hour of purified air per person only for a short time, a matter of a few hours, and expect that once conditions permit shifting the ventilation

¹²⁵*Ibid.*, p. 107.

¹²⁶According to Yegorov, *et al.*, *Grazhdanskaia Oborona*, 3rd edition, p. 115 in English translation, at 50°F brick absorbs 315 kilojoules/hour/m²; stone 378, and reinforced concrete 462; and at 77-86°F brick absorbs 71 kilojoules/hour/m²; stone 88, and reinforced concrete 100.

system to the "pure air ventilation" mode, the additional volume of air provided will remove the excess heat which has built up during the use of minimum ventilation. Presumably, this can be accomplished by the volume of "pure air" prescribed for the shelter in accordance with the climatic conditions where it is located.¹²⁷ In any event, the table suggests that in a shelter built of cast reinforced concrete, the minimum floor space of 0.5 m²/person is acceptable for the initial temperature condition in the range of 50-77° F, with volumes of ventilation of 4-14 m³/hour per person. In the case of expedient shelters Soviet publications also note the need for greater than minimum floor space and surface of enclosing structure per person. For example, it is said that in the median climatic zone of the USSR a wooden vegetable storage shed used as a fallout cover should provide 2-3 m² of surface of the enclosing structure per person, and 4-5 m² per person in the southern region; and it is also recommended that not less than 1 m² of floor space per occupant be provided.¹²⁸ Again, when adapting basements in single-story buildings for use as radiation cover with natural ventilation, it is recommended that 1-1.5 m² of floor space per person be allowed.¹²⁹ From a practical point of view, the minimum floor space per person will, in any event, be greater than 0.5 m² if account is taken of the aisles and other floor area in the shelter not used by the occupants for sitting. For example, the following table reflects the actual floor space per person for several types of expedient shelters.

TABLE 4
Dimensions of Sections of Expedient Detached Shelters
and Total Space per Occupant¹³⁰

Capacity of structure in number of occupants	Construction Materials			
	Reinforced Concrete Elements in Lengths		Round Timber	
	6 m	3m	Single Space Structure	Two-Space Structure
	Dimensions of Shelter Sections in m ²			
50	8×8 (1.28 m ² /p)	5×13 (1.30 m ² /p)	5×20 (2.0 m ² /p)	6×14 (1.68 m ² /p)
100	8×13 (1.04 m ² /p)	5×20 (1.00 m ² /p)	5×33 (1.65 m ² /p)	6×26 (1.58 m ² /p)
150	8×18 (0.96 m ² /p)	5×28 (0.93 m ² /p)	—	6×36 (1.44 m ² /p)
300	8×36 (0.9 m ² /p)	5×53 (0.88 m ² /p)	—	—
300	16×18 (0.96 m ² /p)	—	—	—

¹²⁷Apparently, this point was misunderstood in the translation of the 1970 Soviet civil defense manual by Yegorov, *Civil Defense*, p. 78, fn, ORNL-TR-2793, prepared by the Oak Ridge National Laboratory.

¹²⁸Gorshkov, *Kak Postroit'*, p. 32.

¹²⁹Molodykh, *et al.*, *Protivoradiatsionnye*, p. 11.

¹³⁰Ostroukh, *Stroitel'stvo*, p. 9.

B. Water and Food Reserves

Long-term shelter occupancy requires the provision of water and food for the occupants. Soviet publications cite several minimum requirements per person for daily drinking water. Some cite a minimum requirement of 3-4 liters per person per day,¹³¹ while others cite 5-7 liters per person per day.¹³² In addition, it is recommended that 4 liters per person be provided for hygienic needs "for the entire calculated stay" in the shelter, and in shelters with a capacity for 600 persons and more it is recommended that a reserve of 4.5m³ of water be maintained for extinguishing fires.¹³³ If the shelter toilets are tied in with the municipal sewage system, additional water, up to 16-20 liters per person, is required. According to a 1970 civil defense handbook a shelter with a capacity for 300 people will require a daily supply of about 7 m³ of water of which 1 m³ (270 gallons) is for drinking and 6 m³ [1,620 gallons] is for operating the sewer system.¹³⁴

Normally, permanent shelters will be hooked up to the municipal water system. Large shelters may also have their own artesian wells. The normal water system, however, is expected to be destroyed in the event of a nuclear attack, and consequently, there should be an emergency water supply reserve in the shelters. This emergency supply is stored either in flow-through pressure reservoirs or in non-pressurized containers equipped with removable covers, float valves and water-level gauges. The flow-through reservoirs are usually made of steel pipes, 40 cm or more in diameter, provided with valves and are hung under the ceiling in the sanitary compartments.¹³⁵ The non-pressurized water storage reservoirs are located in separate compartments and are filled only in time of emergency. If permanent reservoirs are lacking, as in expedient fallout covers, in an emergency use can be made of barrels, buckets and other containers with hermetically sealing lids to store water.¹³⁶ A supply of chlorinated lime or two-thirds basic salts of calcium hypochlorite DTS-GK is maintained in the shelter to purify the water. Expedient blast and

¹³¹Kammerer and Kharkevich, *Ekspluatatsiia Ubezhihch*, p. 64; Yegorov, et al., *Grazhdanskaia Oborona*, 2nd edition, p. 196; Krotkov, *Meditsinskaia*, p. 22; Onufriev and Danilevskii, *Spravochnik*, p. 10.

¹³²Yegorov, et al., *Grazhdanskaia Oborona*, 3rd edition, p. 117 in English translation; Ostroukh, *Stroitel'stvo*, p. 96.

¹³³Yegorov, et al., *Grazhdanskaia Oborona*, 3rd edition, p. 117 in English translation.

¹³⁴*Ibid.*, 2nd edition, p. 196.

¹³⁵*Ibid.*; Kammerer and Kharkevich, *Ekspluatatsiia Ubezhihch*, p. 64.

¹³⁶*Ibid.*, p. 65.

fallout covers should have a drinking water reserve calculated on the basis of 600 liters per 100 persons.¹³⁷

Soviet publications are less specific concerning food reserves. Soviet sketches of standard basement shelters include storage rooms for food,¹³⁸ and Soviet human sources confirm that such rooms are included in shelters built in recent years in non-industrial as well as industrial shelters. It is noted, however, that the food storage room may be omitted during the construction of the shelter¹³⁹ which appears to often be the case. According to some Soviet publications, the occupants should plan on a daily food intake of 1600-1800 calories.¹⁴⁰ It is noted, however, that experiments conducted in Alaska in 1950 "demonstrated that under extreme conditions it can be decreased to 400-500 kcal per person per day."¹⁴¹

Soviet civil defense has not developed special long-storage food rations for shelter occupants. Instead, food to be brought to the shelters consists of storable types such as biscuits and hardtack, canned food, concentrates, dried fruit, powdered eggs, and smoked sausage, all of which will not require heating for consumption.¹⁴² It is recommended that when ordered to take cover the occupants of the apartment shelters bring several days' food supply with them. In addition, or alternatively, "food may be delivered from nearby food stores, restaurants and other trade organizations and institutions of public feeding."¹⁴³ Arrangements to stock factory shelters in an emergency with food from the factory restaurants and canteens also exist, and indeed reference is made to such reserves in civil defense exercises.¹⁴⁴ At least one human source reported that in the event of a threat of attack, his instructions were to move as much of his supplies as possible into the basement of his store. Of course, in the event of a strategic warning of an attack the authorities could issue instructions to distribute the food supplies, and undoubtedly would stock

¹³⁷Yegorov, *et al.*, *Grazhdanskaia Oborona*, 2nd edition, p. 200; 3rd edition, p. 123 in English translation.

¹³⁸*Ibid.*, p. 181; 3rd edition, p. 106 of English translation; Titov, *et al.*, *Grazhdanskaia Oborona*, p. 35; Onufriev and Danilevskii, *Spravochnik*, pp. 3, 10.

¹³⁹Titov, *et al.*, *Grazhdanskaia Oborona*, p. 35.

¹⁴⁰Kammerer and Kharkevich, *Ekspluatatsiia Ubezshishch*, p. 111.

¹⁴¹Krotkov, *Meditsinskaia*, p. 22.

¹⁴²*Ibid.*; Kammerer and Kharkevich, *Ekspluatatsiia Ubezshishch*, p. 111; Onufriev and Danilevskii, *Spravochnik*, p. 10.

¹⁴³Kammerer and Kharkevich, *Ekspluatatsiia Ubezshishch*, p. 111.

¹⁴⁴Captain V. Zhitarenko, "Civil Defense Readiness," *Krasnaia Zvezda*, January 21, 1976; Radio Tallin, April 22, 1977, cited in *Soviet Analyst* (London), No. 23, November 24, 1977, p. 7.

the shelters for the essential workers who would remain in the target areas.

C. Sewage System

The sanitation system in shelters is figured on the basis of one toilet for 50-75 persons, but not less than two. Where possible, separate toilets are provided for men and women. If the shelter has flush toilets, they will be connected to the existing sewage network. If the toilets are lower than the sewage pipes, a small electric pump will be installed to lift the waste to the level of the sewage pipes. In the event that the municipal water and sewage system breaks down, there should be stationary or portable waste buckets or containers figured on the basis of 6-7 liters per person per day while the dry waste can be collected in plastic bags.¹⁴⁵ Alternatively, waste boxes or cesspools may be provided with a capacity sufficient to ensure the collection of waste and fecal matter for the anticipated duration of occupancy by the prescribed number of shelter occupants.¹⁴⁶ Normally, expedient covers will be provided with bucket toilets. If the buckets cannot be emptied outside, the full ones will be stored in the entrance passageway to the fallout cover.

D. Heating

Despite the fact that the heat generated by the occupants will quickly raise the temperature inside the shelter, heating is desirable, especially in the northern climatic zones, and is also needed to prevent the shelter from becoming excessively damp. Basement blast shelters can be heated by extending the central heating system of the building to the shelter. Dampers and valves are installed on the line to regulate the heat and to close off the pipes in the event of damage to the building. Normally, the heating requirement is to maintain the shelter temperature at 10° C (50° F) during the cold weather.¹⁴⁷ Detached shelters and expedient fallout covers of the basement or dugout type may have wood-burning stoves,¹⁴⁸ although in most instances expedient shelters will not be provided with heating systems.

¹⁴⁵Krotkov, *Meditinskaia*, p. 22; Yegorov, *et al.*, *Grazhdanskaia Oborona*, 2nd edition, p. 199; Onufr *ev* and Danilevskii, *Spravochnik*, p. 10.

¹⁴⁶Yegorov, *et al.*, *Grazhdanskaia Oborona*, 2nd edition, p. 199; 3rd edition, p. 123 in English translation.

¹⁴⁷*Ibid.*, 3rd edition, p. 117 in English translation.

¹⁴⁸Molodykh, *et al.*, *Protivoradiatsionnye*, pp. 27, 28.

E. Doors and Entrances

In the design of Soviet shelters and fallout covers, a great deal of attention is paid to the layout of entrances and the installation of protective doors. In the case of shelters, the number of entrances and the dimensions of the protective doors depend on the number of shelter occupants. The dimensions of the entrance doors are figured on the basis of 0.80×1.80 meters for every 200 persons, or 1.20×2.00 meters for every 300 persons, and they are provided with a 15 cm-high threshold.¹⁴⁹ The doors must be placed so as to not be directly exposed to the shockwave, and should "withstand a load exceeding by two-three fold the excess pressure in the front of the shockwave."¹⁵⁰ In effect, the doors must be protected by right angle entrances from the outside. If there is more than one entrance, they should be located at opposite sides of the shelter.

The entrance doors must not only be sufficiently strong to withstand the shockwave but must also be fireproof and ensure a hermetic seal to prevent any seepage of smoke, toxic gases or water into the shelter. Several types of door designs exist. They are either all metal, or metal with a concrete center; or, if these are not available, wooden doors covered with metal. Steel is most widely used for exterior doors, which are edged with a rubber gasket to ensure a hermetic seal, and are equipped with plate wedge locks or wheel-locking mechanism. If the door is made of steel plates, they must be at least 12 mm (0.5 in.) thick.¹⁵¹ The doors are either flat or cylindrically convex or concave, with a concrete filler.¹⁵² The entrances are also provided with an inside door, either of the same type as the outside one, or somewhat lighter in construction (may use 4 mm-thick steel plates.)¹⁵³ The two doors should be at right angles to each other and form an air lock between them, 1.4×1.4 m, or 1.6×1.6 m in size.¹⁵⁴ In large capacity shelters a double air-lock entry may be used. If the outer door is not fireproof, it is desirable to install three doors, with two interim sealed doors, one opening into the air lock and the other into the shelter area.¹⁵⁵

¹⁴⁹Yegorov, *et al.*, *Grazhdanskaia Oborona*, 3rd edition, p. 106 in English translation; Kammerer and Kharkevich, *Ekspluatatsiia Ubezshishch*, p. 10; Onufriev and Danilevskii, *Spravochnik*, p. 3.

¹⁵⁰*Ibid.*, p. 16.

¹⁵¹Iakubovskii, *Grazhdanskaia Oborona*, p. 49.

¹⁵²Onufriev and Danilevskii, *Spravochnik*, pp. 16-17.

¹⁵³Iakubovskii, *Grazhdanskaia Oborona*, p. 49.

¹⁵⁴*Ibid.*; Kammerer and Kharkevich, *Ekspluatatsiia Ubezshishch*, p. 10.

¹⁵⁵Onufriev and Danilevskii, *Spravochnik*, p. 4.

Detached and expedient shelters and fallout covers should have right angle covered entrances, and those of a permanent type should also have double hermetically-sealing doors designed to sustain the same load as the main structural members of the shelter.¹⁵⁶ The outside doors should be made of metal or thick wooden boards (over 10 cm thick), mounted on metal ribs.¹⁵⁷ The inside doors are made of wood and are less heavy. The protective door must be placed so as to transmit the pressure of the shockwave on it to the structural members of the entrance and the main structural members of the shelter or cover. Simple expedient fallout covers may have only one wooden door (made of a layer of plastic or rubberoid between two layers of wooden boards) and a cloth curtain as a second protection against the penetration of radioactive dust, or may have two curtains with a small vestibule between them.

F. Miscellaneous Shelter Equipment

As was noted, the shelter contains a variety of equipment, which is used for various purposes. In order to monitor the air pressure in the shelter, there should be a hydrostatic or inclined manometer, and to measure the temperature and humidity, there should be one or more psychrometers or moisture meters. In order to measure the amount of air provided by the ventilation system and the amount being drawn out by the exhaust, the shelter should have one or more anometers and rotometers. There may also be instrumentation to measure the CO₂ content in the air.

The shelter will have one or more remote-reading radiation meters and dosimeters. One type, Model DP-64, is battery powered and operates in the follow-up mode, providing an audio and light signal when the level of gamma radiation reaches 0.2 r per hour.¹⁵⁸ Another, Model DP-3B, measures gamma radiation on four scales: 0.1 r/hour, 1-10 r/hour, 10-100 r/hour, and 50-500 r/hour.¹⁵⁹ The civil defense shelter team will also be provided with a chemical agent detection kit, rubber gloves, and chemical decontamination packets, in addition to protective suits and gas masks.

In addition to a telephone, radio receiver (and in special cases, radio transmitter), and two medical first-aid kits, the shelter is provided with 1-4 fire extinguishers. In case of damage to the shelter, or in the event that the exits are buried under debris, the shelter equipment includes

¹⁵⁶Ostroukh, *Stroitel'stvo*, p. 37.

¹⁵⁷*Ibid.*, p. 39.

¹⁵⁸"The DP-64 Indicator Signalling Device," *Voennye Znaniia*, No. 2, February 1976, p. 24.

¹⁵⁹"Radiation Meter DP-3B," *Voennye Znaniia*, No. 4, April 1976, p. 49.

axes, crawlers, pick axes, sledge hammers, metal hacksaws, borers and manual drills, hammers, chisels, and shovels, as well as flashlights, candles and emergency lighting. For the most part, however, such equipment will be lacking in expedient blast shelters and fallout covers.

G. Soviet Views on Duration of Shelter Occupancy

Unlike in the West, Soviet civil defense does not prescribe a specific duration for shelter occupancy, and the provisioning of Soviet shelters and fallout covers with water, food and medical supplies does not appear sufficient in most cases to allow a shelter occupancy of two weeks or more. Of course, these limits do not apply to the special shelters for the elite or command posts. The Soviet view is that the duration of mandatory stay in shelters would depend on local radiation conditions, and that as soon as possible the shelter occupants should be moved to nearby undamaged buildings or evacuated to safe areas, taking into account that the permissible one-time dose of exposure to radiation should not exceed 50 r, although it is likely that when necessary the authorities will allow a single radiation dose of as much as 100 r. In any event, a cumulative dose of 100 r over a period of ten days is said to be safe. The following table suggests the duration of shelter occupancy as a function of the levels of radiation.

TABLE 5
Length of Time People Must Remain Under Cover¹⁶⁰

Levels of Radiation 10 hours After Detonation in r/h

	0.5- 1.25	2.25- 2.5	2.5-5	5-10	10-15	15-20	20-25	over 25
Time of Mandatory Stay in Shelter in days	Not Mandatory ¹⁶¹			1-2	2-3	3-4	4-5	over 5
Time of Mandatory Stay Indoors in Buildings (after leaving shelter)	0.5	1	1	1-2	2-4	4-7	7-15	over 15

¹⁶⁰Iakubovskii, *Grazhdanskaia Oborona*, p. 67.

¹⁶¹Krotkov, *Meditsinskaia*, p. 20, suggests a shelter stay of some 10 hours for a radiation level of 0.5 r/hour ten hours after the blast.

Soviet publications note that with a radiation level of 240 r/hour one hour after the blast, it will require a week for it to decline to a level of 0.6 r/hour, and that a level of 1,000 r/hour one hour after the blast will require two weeks to decline to a level of 1 r/hour.¹⁶² It is also stated that with radiation levels of 5 r/hour to 25 r/hour ten hours after the blast, shelter occupants will be able to leave the shelters during the first two days for 20-40 minutes per day; for 1-2 hours "if absolutely necessary" the subsequent days; and for 3-4 hours per day during the period of mandatory stay inside buildings.¹⁶³ In principle, therefore, the shelter and building occupants could forage for food and water during these permissible short duration ventures into the open.

It appears likely that, in most instances, there will be sufficient water, food and toilet capacity to allow people to stay under cover for three, and possibly five days. The possibility of remaining longer will depend, in part, on whether the shelter is located in a zone of significant damage and, consequently, is without electric power (unless it is provided with its own diesel generator), water and sewage, or whether these facilities remain intact and can be used to maintain the operation of the shelter equipment. In principle, persons in shelters located in the zone of destruction or severe damage will be rescued by the Civil Defense forces, which will enter these zones as soon as the radiation levels permit, to conduct rescue, damage-limiting and emergency repair operations, and to clear and decontaminate access routes leading to nearby radiation-free areas. Even so, it appears the shelter occupants in areas of high levels of radiation (i.e., in excess of 1,000 r/hour one hour after the blast) will be in trouble and may be forced to leave the shelters prematurely, or at least to risk some of the members in order to forage for food and water.

Control over shelter occupants in excess of 50 persons and up to 300 or even more, and operation of the shelter equipment is exercised by a Civil Defense shelter team composed of a team commander and six members, who work two twelve-hour shifts. The team ensures that the shelter is ready for occupancy, and if it is used for other purposes in peacetime, the team clears the shelter when a threatening situation is announced by the authorities. At the moment an "air alert" is sounded, the team reports to its assigned shelter, opens the doors, turns on the ventilation system, lights, etc. While the shelter is being filled, one shelter team member remains outside the main entrance to admit the people to the shelter and maintain order, while a second member stands by the inside door and directs the arriving occupants to their seats. The other

¹⁶²Yegorov, *et al.*, *Grazhdanskaia Oborona*, 2nd edition, pp. 81, 82.

¹⁶³Iakubovskii, *Grazhdanskaia Oborona*, p. 68.

team members monitor the operation of the filter-ventilation system and stand by to close it down in the event of a nuclear detonation, or to switch it to a "filter-ventilation" mode of operation. Other team members close the shutters to the emergency exit, check the hermetic seals of all doors, adjust the ventilation exhaust system, check the operational readiness of the standby diesel electric generator if such is present at the shelter, and so on. The team is instructed to close the shelter doors once the shelter is fully occupied, or, in the event that the authorities sound the "close shelters" warning signaling an imminent attack. Such signals will be given over the radio loudspeaker and/or by telephone. Following an attack, the shelter team maintains discipline among the occupants, monitors the shelter equipment and external conditions, determines the appropriate modes of operation of the ventilation system, helps to provide first aid to occupants, and, if the shelter is damaged or buried under debris, directs the occupants in repair work or in the evacuation of the shelter.¹⁶⁴ If the shelter is undamaged, the team will instruct the occupants according to the signals issued by the Civil Defense command post and, presumably, no one will leave the shelter unless specifically instructed to do so. During the stay in the shelter the shelter commander will organize other teams from among the occupants to assist him in such activities as food distribution, care of young children and the sick, removal of fecal buckets, water distribution, and so on. Generally, fallout covers and expedient shelters are not provided with shelter teams, especially if their capacity is less than 50 persons. In this case, the authorities rely on the basic training of the general population to teach the occupants the correct use of the simple shelter ventilation system. Presumably, in the areas outside the blast zone, the shelter occupants will be instructed on what measures to take, and when to leave the shelters by siren signals and, if necessary, by messengers from the Civil Defense command posts.

¹⁶⁴Yegorov, *et al.*, *Grazhdanskaia Oborona*, 3rd edition, pp. 137-138 in English translation; Kammerer and Kharkevich, *Ekspluatatsiia Ubezhiishch*, p. 148-154.

CHAPTER FIVE

Shelter Availability, Readiness and Cost

The Soviet civil defense authorities do not publicize the amount of ready shelter space in the USSR, the distribution by type, or the state of readiness. Precise estimates of these capabilities, therefore, are not possible. Even so, published Soviet references to existing shelters and local shelter capabilities over the years, photographs of such shelters, reports by travelers, and data provided by recent Soviet emigres allow some gross estimates of Soviet shelter capabilities at the present time.

It must be kept in mind that shelter construction in the Soviet Union began in the late 1940s and has proceeded with varying degrees of priority ever since. As was noted, the emphasis on pre-attack evacuation and dispersal of people in potential target areas was explained on the ground that there were insufficient "reliable shelters," and that the construction of such shelters for the entire population was too costly. Conversely, Altunin seemed to claim in 1976 that a sufficient number of shelters had been built by the early 1970s to permit placing primary reliance on shelters as a means of protecting the population and to justify the call for providing shelters for the "entire" population.¹⁶⁵ Even at the beginning of the 1960s, however, there was solid evidence from Soviet sources and observations by foreign travelers that "numerous" shelters existed in the large cities at industrial enterprises, in public buildings and apartment houses, and that the subways in Moscow and Leningrad had been equipped with blast doors.¹⁶⁶ There was also considerable evidence of ongoing shelter construction during the 1960s, primarily in conjunction with industrial enterprises and schools, but also including public buildings, office buildings, some apartment houses, and even collective farms.¹⁶⁷ By 1970, it was said that "the state devotes great attention to the preparation of protective structures."¹⁶⁸ The then Chief of USSR Civil Defense, Marshal of the Soviet Union V. I. Chuikov, asserted in 1971 that "the inventory of such shelters is progressively increasing,"

¹⁶⁵Altunin, "Principal Stages," p. 45.

¹⁶⁶The *New York Times*, March 23, 1962; *Washington Post*, March 25, 1962; Gouré, *The Soviet Civil Defense Shelter Program*, pp. 4-5; and *Civil Defense in the Soviet Union* (Berkeley: University of California Press, 1962), *passim*.

¹⁶⁷Gouré, *Soviet Civil Defense Revisited, 1966-1969*, RM-6113-RR, The Rand Corporation, November 1969, pp. 26-27.

¹⁶⁸Kachu!in, *Beseda*, p. 32.

although other sources indicated that the role of such construction in various parts of the country was uneven.¹⁶⁹ A survey of various Soviet publications for the period 1969-1970 found references to factory shelters in nineteen Soviet cities located in all parts of the Soviet Union.¹⁷⁰ There were also references to basement shelters in apartment houses and in new buildings under construction in various cities. In the same period, it appeared that increased attention was paid to the construction or adaptation of fallout covers in rural areas.¹⁷¹ Similarly, a survey of such Soviet publications in 1976 found mention of shelters in thirty Soviet localities. A description of civil defense activities at the Moscow First State Ball Bearing Plant, published in 1975, described not only the available shelters at the plant, but also plans for construction of additional ones for the workers' residential settlement, and during the course of renovation and modernization of the plant, as well as the building of a "large underground pedestrian walkway-shelter," of a vehicular tunnel and underground garage adapted for use as shelters; the "adaptation of all available basements in production and residential buildings as shelters"; the construction of protected wells, water reservoirs, pumping and compressor stations, and so on.¹⁷² The Civil Defense chief of staff of Tiraspol, Moldavia SSR, claimed that "the number of shelters in the city is being increased yearly," and that "new national economic projects are being constructed and existing ones modernized with regard to the engineering-technical norms [i.e., protective norms] of civil defense."¹⁷³

In Moscow, new housing projects are being built increasingly with underground garages which are adapted for use as shelters, and various multistory underground complexes of stores, warehouses, garages, vehicular tunnels and walkways are reported to be under construction.¹⁷⁴ Published Soviet accounts of civil defense exercises also report the construction of expedient shelters in the cities and at collective and state farms. During a two-day exercise held in 1975 at the town of Lytkarino (population about 40,000), a satellite town of Moscow, the 14,000 residents of one of the town's districts are said to have had sufficient ready

¹⁶⁹*Voennye Znaniia*, No. 2, February 1971, p. 5; *Sovetskaia Moldaviia*, February 18, 1970; Colonel K. Kipriian, "The Role of Shelters," *Sovetskan Haiastan (Soviet Armenia)*, February 27, 1970.

¹⁷⁰Gouré, *Soviet Civil Defense 1969-1970*, (Coral Gables: Center for Advanced International Studies, University of Miami, 1971), p. 23.

¹⁷¹*Ibid.*, p. 24.

¹⁷²Gromov and Krechetnikov, *Grazhdanskaia Oborona Promyshlennogo*, *passim*.

¹⁷³Colonel V. P. Semenchuk, "To Find Support in the Aktiv," *Sovetskaia Moldaviia*, October 10, 1975.

¹⁷⁴*Pravda*, August 23, 1973; A. Blokin, "Underground Streets," *Izvestiia*, April 10, 1974.

shelter space to take cover when a test alert was sounded.¹⁷⁵ Similar exercises have been held in other towns and settlements throughout the USSR. These exercises also serve to speed up the construction and equipping of shelters and the building of expedient blast shelters and fallout covers, which can be "gradually" strengthened and improved thereafter in order to transform them into "real permanent protective installations."¹⁷⁶ Altunin wrote in 1975 that "in the course of the preparation and execution of complex factory exercises, it is *obligatory* to carry out the forced-draft construction of protective structures and training sites."¹⁷⁷ In addition, account should be taken of the growing number and capacity of Soviet subway systems as a part of the overall Soviet shelter capability. Apart from the six subways now in operation, a subway system is under construction in Tashkent, and plans have been made for the construction of subway systems in Minsk, Gor'kiy, Novosibirsk, Sverdlovsk, Kuibyshev and Riga.

In addition to the hundreds of statements concerning, and photographs of, shelters in Soviet publications and observations by knowledgeable travelers in the USSR, interviews with sources who have recently left the Soviet Union, which were conducted as a part of this study, proved very informative concerning the existence and availability of shelters in the Soviet Union. All of the twenty-seven sources interviewed by the author had personal knowledge of shelters in twenty-one Soviet cities, including the largest ones, which were located in both European Russia and Siberia. Among them were eight persons who had worked in architectural design bureaus and technical or construction agencies, and were directly involved in the design, building or inspection of shelters. The following is a summary of the findings provided by these interviewees concerning shelter availability in the Soviet Union, as of 1974-1976.

- a. There are special shelters and underground complexes for the use of the leadership and high-ranking party officials.
- b. All ministries and major administrative agencies have shelters.
- c. All headquarters of the armed services have special extra-hard, multistory shelters.
- d. The buildings occupied by important KGB officers have shelters.

¹⁷⁵Captain V. Zhitarenko, "Civil Defense Readiness"; Major General M. Rakcheev, Chief of Civil Defense Staff of Moscow Oblast, "When the Siren Sounded," *Sovetskii Patriot*, June 9, 1976.

¹⁷⁶Altunin, "The Main Direction," p. 7; "On the Basis of What Has Been Achieved," *Voennye Znaniia*, No. 10, October 1975, p. 4.

¹⁷⁷*Ibid.* See also Colonel A. Zaitsev, "The First Lesson: The Time Has Come to Glean Them for Complex Exercises Already Held at Production Facilities," *Voennye Znaniia*, No. 6, June 1976, p. 18.

- e. Communist Party agencies at the national, republic, oblast, city and city-district (*raion*) levels have shelters.
- f. All important large governmental administrative agencies and organizations, and headquarters of national public "voluntary" organizations have shelters.
- g. All industrial enterprises with their own buildings have either basement or detached shelters with sufficient space for at least one workshift. Important defense-related plants in many instances have multistory, underground production facilities, and in some instances are entirely underground.
- h. Small enterprises which do not have their own building usually have a shelter in the basement of the building they occupy or designated space in nearby shelters, unless they are located close to a subway station. In a number of instances, the sources reported that their enterprise or a portion of it was normally located in a shelter.
- i. All significant communications facilities apparently have shelters.
- j. A significant number of shelters appear to be located in conjunction with railroad and river transportation stations. Whether such shelters exist at major airports and large bus stations is not clear.
- k. A vast majority or all of the secondary and, presumably, large primary schools have shelters.
- l. A vast majority or all institutions of higher learning, technical and vocational schools have shelters.
- m. All hospitals in large cities have shelters.
- n. A large proportion of scientific and technical institutes and large laboratories have shelters.
- o. There are numerous shelters in conjunction with stores, public service buildings (*dom byta*), theaters, and food processing and storage facilities.
- p. All interviewees knew of shelters in apartment buildings. The majority had such shelters in the buildings where they had lived and had relatives living in buildings with shelters. Those who did not have shelters in their own apartment building knew of basement shelters in nearby buildings.
- q. All interviewees who had lived in cities with a subway system knew that the subways were designated as shelters and that the stations were equipped with protective blast doors.
- r. All Civil Defense headquarters have shelters.
- s. The interviewees indicate the existence of standby underground Civil Defense command posts outside the cities for republic, oblast and large city Civil Defense staffs.

- t. Some interviewees knew of underground pedestrian walkways adapted for shelter purposes in a number of cities and of shelters in special work areas such as large sea ports.
- u. A number of interviewees estimated that sufficient shelters exist at the present time for 70 percent of the industrial labor force.

The following table is a tentative estimate of ready Soviet shelter capacity in urban areas and at industrial enterprises, as reflected by information provided in Soviet publications and interviews with Soviet citizens who have recently left the Soviet Union, and based on 1975 Soviet population and employment statistics.¹⁷⁸

The percentages of shelter capacity assigned to the various categories of the population are admittedly impressionistic. The numbers used for party cadres, KGB and other elite elements are fairly arbitrary, but likely to err on the low side. It is possible that some estimates, (for example, shelter space for students in institutions of higher learning), are a bit high because some of them may be night or part-time students. To balance this off, however, certain categories of Soviet citizens, a portion of whom are likely to be provided with shelters on a priority basis, are not included, such as civilian employees of military and military-related administrations; various categories of municipal employees (numbering some 3.8 million), school teachers and employees of ministries, administrations and institutions of education (numbering 8.1 million); employees of cultural organizations and artists (numbering 1.5 million); and employees of financial and credit institutions (numbering 0.5 million). The shelter count for these categories could be added to the total, or could be considered as balancing out any inflation of shelter estimates in Table 6. The evidence provided by Soviet literature, travelers, and human sources suggests that the estimate of 25 percent shelter capacity at non-employment related locations, i.e., apartment houses, some types of public buildings, parks, underground walkways, subways, caves, and so on, is most probably quite conservative. Thus, despite uncertainties, it appears realistic to assume that at this time sufficient shelter space exists for some 60 percent of the Soviet urban population in the potential target cities,* and for at least 70 percent of those elements of the population which the Soviet authorities view as valuable or essential for the

¹⁷⁸Central Statistical Administration of the Council of Ministers of the USSR, *Narodnoe Khoziaistvo SSSR v 1975* (Moscow: Statistika, 1976), *passim*.

*According to available sources, priority in blast shelter construction has been given to those cities and towns which the Soviet authorities assume to be likely targets for nuclear strikes. Presumably, these include industrial, administrative and transportation, and centers of fuel, energy, and raw material production, as well as defense-related localities. Presumably, too, most or all cities with 50,000 inhabitants or more will be included, as well as some, but not all, towns with 10,000 inhabitants, and in a few cases, smaller ones.

TABLE 6
Estimate of Ready Blast Shelter Capacity in 1975-1976

Total Population	256.7 million		
Total Urban Population	156.6 "		
Population in Cities With Over 10,000 Inhabitants	136.3 "		
Population in Cities With Over 50,000 Inhabitants	103.1 "		
Industrial Work Force	34.0 "		
Shelters for 70% of Industrial Work Force		23.8 million	
Shelters for 50% of Industrial Work Force		17.0 "	
Communications Workers	1.5 "		
Shelters for 50% of Communications Workers		0.7 "	
Government and Administration Workers	2.2 "		
Shelters for 70% of Administration Employees		1.5 "	
Shelters for Core Party Cadres, KGB and Other Elite Elements		0.2 "	
Public Health Workers	3.3 "		
Shelters for 50% of Public Health Workers		1.6 "	
Science Workers	4.0 "		
Shelters for 70% of Science Workers		3.0 "	
Trade and Public Feeding Employees	8.8 "		
Shelters for 20% of Trade Employees		1.7 "	
Rail and Water Transportation Workers	2.8 "		
Shelters for 20% of Transportation Workers		0.5 "	
Students in Urban, Daytime Primary and Secondary Schools	22.3 "		
Shelters for 80% of Students		17.8 "	
Shelters for 50% of Students		11.1 "	
Shelters for 100% of Students in Special Secondary Schools		2.8 "	
Shelters for 100% of Students in Institutions of Higher Learning		9.8 "	
Shelters for 50% of Students in Institutions of Higher Learning		4.9 "	
Shelters for 25% of Urban Population at Places of Residence and at Non-Production Facilities, including Subways		39.0 "	
<hr/>			
Total Estimated Ready Shelter Capacity	84.0 —	102.4 million	
Percentage of Total Urban Population	53% —	64%	

preservation of power and the recovery of the Soviet Union in the event of a war.

How well the distribution of shelters in Soviet cities meets the requirements of the daytime, and especially the nighttime, population distribution cannot be assessed. In general, it appears that there is a greater concentration of shelters at places of employment, which may pose special problems in cities with distinctly separate industrial districts. Presumably, the Soviets may have a problem in having too great a proportion of shelter spaces being concentrated "downtown." It should be noted, however, that new housing developments at the edges of Soviet cities mainly tend to be multistory apartment houses rather than individual homes, as is often the case in the United States, and that there are indications that these apartment buildings are often provided with shelters or dual-purpose shelter-garages.

Another area of uncertainty is the extent to which the basement shelters have been fully equipped. Human sources report various instances of basements being designed to meet the strength requirements for use as shelters, but lacking the filter-ventilation equipment, the production of which is possibly lagging behind demand. If such basements were to be used in an emergency, they would be habitable in most cases for only 4-6 hours after the doors are closed.¹⁷⁹

Comprehensive information is also lacking on the cost of the Soviet urban shelter construction program to date. Estimates based on official Soviet price indexes for various materials may be misleading because building organizations often pay higher prices for hard-to-get materials, are very wasteful and inefficient, and tend to over-insure by using more materials than strictly necessary. Shelter construction cost figures cited by knowledgeable sources generally are in agreement that the current cost of basement blast shelters in multistory buildings is on the order of 500 rubles to 1,000 rubles per occupant. According to them, standard detached blast shelters cost one-third more because of the added cost of excavation, earth moving, waterproofing, and the special extension of water and sewage pipes and electric cables, which are not normally included in the cost of basement shelters. Obviously, the super-hard and extra-hard shelters and the multistory industrial shelters cost a great deal more per person, as does the cost of making the subway systems deeper than would otherwise be necessary and providing them with special protective equipment. If one assumes an average shelter cost of 500 rubles per person, then on the basis of the estimates of ready shelter capacities in Table 6, the total cost of shelter construction would be on the order of 42 to 51.2 billion rubles. Prorated over 20 years, this would

¹⁷⁹Iakubovskii, *Grazhdanskaia Oborona*, p. 33.

mean an annual cost for shelter construction of 2.1 to 2.5 billion rubles/year. A lower cost figure could also be used in order to take into account the fact that a portion of the shelters is in basements of older buildings, built before World War II, requiring only some reinforcing in addition to equipping them with doors and filter-ventilation units. If one were to assume, therefore, an average cost per occupant of 250 rubles, then the total cost of the estimated ready shelters would be on the order of 21-25 billion rubles, or, over a 20-year period, 1 to 1.2 billion rubles/year.

While this lower average cost per occupant over the past 20 years appears plausible, it should be kept in mind that current shelter construction is primarily undertaken in conjunction with the building of new industrial facilities, official buildings and housing developments. A substantial part of such underground structures may have a dual-purpose character and also includes detached shelters, some of which, according to sources, are being built at great cost in very unfavorable terrain. The cost of such new construction is likely to be closer to the 500 rubles/person reported by human sources. If, furthermore, account is taken of additional construction of extra-heavy shelters, underground industrial production facilities, underground protected storage sites, hardening of various utilities, and so on, then it would appear likely that the present annual cost of construction for protected facilities is on the order of 2 billion rubles.

CHAPTER SIX

Conclusions

Given the large amount of resources required for its implementation, the Soviet shelter program, and especially the decision to provide the "entire" urban population with ready shelter space, are a measure of the seriousness with which the Soviet leadership regards civil defense. In the past, when the Soviet authorities emphasized what appeared to be a relatively low-cost program of pre-attack urban evacuation and dispersal as the principal method for protecting the population in the event of a nuclear war, various people in the West argued that the Soviet civil defense program reflected mainly Soviet bureaucratic inertia rather than a belief in the possibility of survival of the population in a nuclear war, and that the evacuation program itself was proof that the Soviet leadership would not and could not execute a surprise counterforce strike on the U.S. The current Soviet shelter program indicates that these assumptions are not valid at the present time, if they ever were. While it is true that in the event of a nuclear exchange casualties among a sheltered population in potential target areas would be greater than if the urban population were dispersed to the rural areas, by the same token, however, with sufficient ready shelters in place, the Soviet leadership has the option of not providing the U.S. with a strategic warning of a Soviet first strike, which would be provided by the massive evacuation of the urban population. Soviet spokesmen now note that "the time period for performing protective civil defense measures may be extremely limited, especially those for carrying out dispersal evacuation."¹⁸⁰ In effect, therefore, the Soviet leadership has both options, i.e., sheltering the population in place, and providing little or no warning to the enemy, or urban evacuation and dispersal, which provides such warning, but could give Moscow major leverage in a crisis situation, especially if the U.S. were unable to disperse, or effectively shelter, its own urban population.

At present, the Soviet Union is still well short of the capability of providing immediate blast protection to its urban population and fallout protection to residents in rural areas. While the Soviet shelter program appears to be moving in such a direction, and considerable ready shelter capacity is already in existence, the present rate of construction of shelters is not known and, consequently, it is not possible to reliably estimate when the "entire" urban population, and possibly the rural population as well, will be provided with protection against nuclear weapons and

¹⁸⁰Kotlukov, *et al.*, *Grazhdanskaia Oborona*, pp. 19-20.

their effects. Some human sources estimated that this construction program may take on the order of three years, but there is little to confirm this opinion. Of course, if an emergency were to occur before the completion of the program, the present indications are that there is sufficient shelter space in existence for use by the majority of what the Soviet leadership considers the more valuable and essential elements of the population.

There is certainly no indication of any slackening of efforts to build up the Soviet civil defense capability, nor any suggestions that the Soviet leadership would be prepared to do so as a part of a new SALT agreement. In an interview published in *Red Star* on February 3, 1978, Army General Altunin declared that "Soviet civil defense at the present stage is an objective necessity, and went on to say that:

When there is a fresh twist to the arms race and the danger of war exists the Communist Party and the Soviet Government are obliged to show unremitting concern for strengthening the state's defense might and raising the combat readiness of the Soviet Armed Forces. As for USSR Civil Defense, it would be strange to deny that certain measures to improve it are being carried out.

The main purpose of our civil defense is, together with the armed forces, to insure the population's defense against mass-destruction weapons and other means of attack from a likely opponent. By implementing defensive measures and thoroughly training the population, civil defense seeks to weaken as much as possible the destructive effects of modern weapons. . . .

Nothing, no heartrending cries from ideologists of imperialism, no fabrications of the bourgeois propagandists, can distract us from solving this important task of the state and of the whole people.¹⁸¹

¹⁸¹"In Defiance of Logic," *Krasnaia Zvezda*, February 3, 1978.